

BAHR'3G

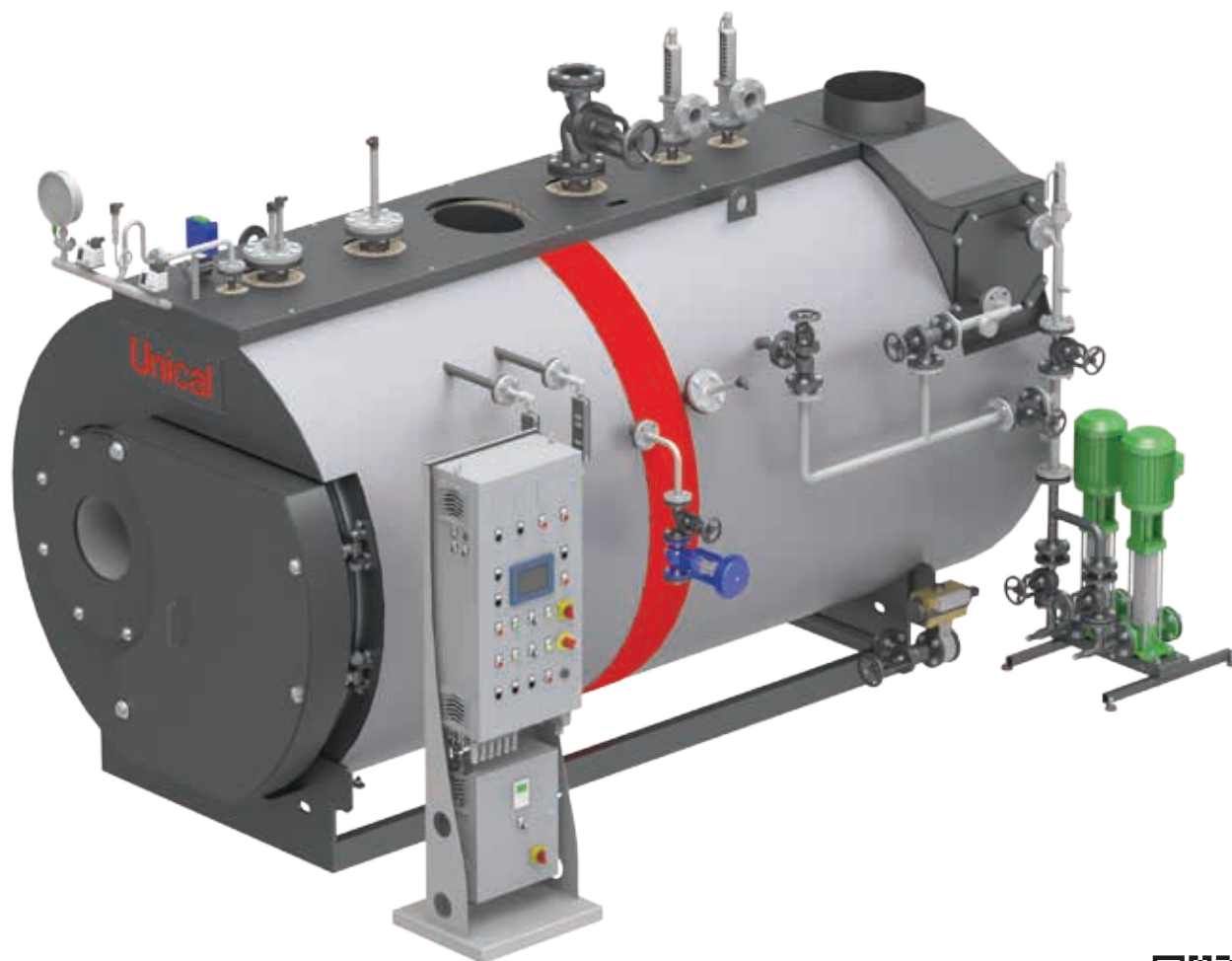

**HIGH PRESSURE PACKAGED STEAM BOILER,
GENUINE THREE PASS FIRETUBE, EFFICIENCY UP TO 96%**

RANGE	from 341 kW (500 kg/h) da 2728 kW (4000 kg/h)					
TYPE	STD			HP		
	smooth pipe			ESALU pipe		
FUEL	gas, light & heavy oil			gas		
DESIGN PRESSURE	12 bar (higher pressure on request)					
MODELS	500	800	1000	1250	1500	1750
	2000	2500	3000	3500	4000	-

DESCRIPTION

High pressure packaged steam boiler, genuine three-pass fire tube, horizontal, from 90% up to 96% efficiency ⁽¹⁾ according the installed smoke tube (HPO, HP).

BAHR'3G is a family of packaged smoke tube steam boilers, genuine three-pass, and wet back. Standard safety pressure up to 12 bar (higher pressure available on request) and output from 500 to 4000 kg/h. With a large steam chamber and large evaporator for an high steam quality. It can be operated with liquid or gaseous fuels. Every model is complete with regulations and safety accessories for automatic operation and easy commissioning.

In compliance to the current laws, each steam boiler undergoes a conformity assessment, carried out by a Notified Body. The conformance to the essential safety requirements demanded by the European Pressure Equipment Directive 2014/68/UE (PED) is guaranteed by the CE mark.

Design features:

By means of the three-pass design the smoke gases in the combustion chamber are diverted to the front through the first set of fire tubes by the reversing chamber; then reversed again by the frontal smoke box to the second smoke tube sections and discharged through the chimney connection. The appliance is designed to ensure low heating loads in the combustion chamber, low superficial loads and low NOx emissions (with Low NOx burners).

■ **Boiler body:** is made of a cylindrical shell and a wet back furnace, flat tube plates, made of high quality steel. All the materials have certificates attesting their chemical and mechanical characteristics, the controls are carried out during each production stage, and, theirs suitability for use as well. The welding seams are carried out by qualified personnel in compliance to certified procedures and are subjected to Non Destructive Tests, in accordance to an internal "Manufacturing and Control" program. Once the boilers have been manufactured they are subjected to hydraulic testing in accordance to the requirement 7.4 – Annex I, laid down in the Directive 2014/68/UE (PED).

■ **Smoke tubes:** made of high quality steel, are welded to tube plates, and are with helical turbulators or special metal extrusions according the version.

■ **Reversing chamber:** is built in welded steel plate, completely water-cooled, and connected to the rear smoke-box with supports.

■ **Front door:** is built in welded steel plate, completely cladded internally with layers of insulating and refractory cement. The door is fitted with hinges to be quickly opened.

■ **Rear smoke-box:** is built in welded steel plate, completely cladded externally with a layer of insulation material. One door for cleaning and inspection are fitted with hinges to be quickly opened. Complete with an horizontal chimney connection with a diameter sized to the boiler's output (vertical on request). The rear smoke-box can be accessorized with and internal removable economizer.

■ **The basement:** is built with a steel frame, welded to the tube plates and closed with steel plates.

■ **Walkway:** positioned on the top part of the boiler, is made of steel, covered with chequered plate and completed; on request with handrail and access ladder.

■ **Insulation:** the shell is thermally insulated with a 100 mm rock wool cladding binded with high density, thick thermosetting resins, suitably supported and covered externally in 10/10 thick enamelled aluminum.

Standard equipment: (2)

- Steam main globe valve.
- 2 spring loaded safety valves.
- 2 reflecting level indicators, with flanged connections, purging and cut-off cocks.
- 1 large manometer with 3 way cock for manometer calibration.
- 1 safety pressure switch with manual reset onto the panel board, CE PED certified.
- 1 limit working pressure switch.
- 1 regulation pressure switch for two stages burners or probe for modulating burners.
- 2 safety minimum level switches, CE certified.
- 2 water level probes for ON-OFF pump regulation.
- Feeding group complete with 2 vertical multistage centrifugal pumps.
- Valve assembly for feeding circuit, with relevant pipes already fitted.
- Automatic group for level control.
- 1 manual bottom blowdown valve.
- Man-hole on top and hand-hole on water side.
- Integral steam drier for high steam quality.
- Blind burner plate.
- Lifting lugs.
- Control panel board IP55 400V - 3+N - 50Hz
- Document folder enclosing:
 - Manufacturer's Declaration of Conformity in compliance with the Annex VII of the European Directive 2014/68/UE (PED)
 - Installation, operation and service manuals.
 - Certificates of safety components.
 - Control board's electric schemes and related Declaration of Conformity.
 - Water characteristics: requirements concerning the quality of water supply, the water in the boiler, frequency and type of sample tests to do.

(1) This value is intended with economizer and may change according working pressure and load conditions.

(2) The quantity and the model may vary according to the configuration.

MAIN COMPONENTS

1. Boiler body
2. Front door
3. Rear smoke chamber (with optional integrated removable economizer)
4. Board panel
5. Instruments assembly
6. Level safety sensors
7. Steam valve
8. Safety valve
9. Automatic bottom blow down (optional)
10. TDS: salinity control/surface blow down (optional)
11. Feed water pump
12. Water level indicator

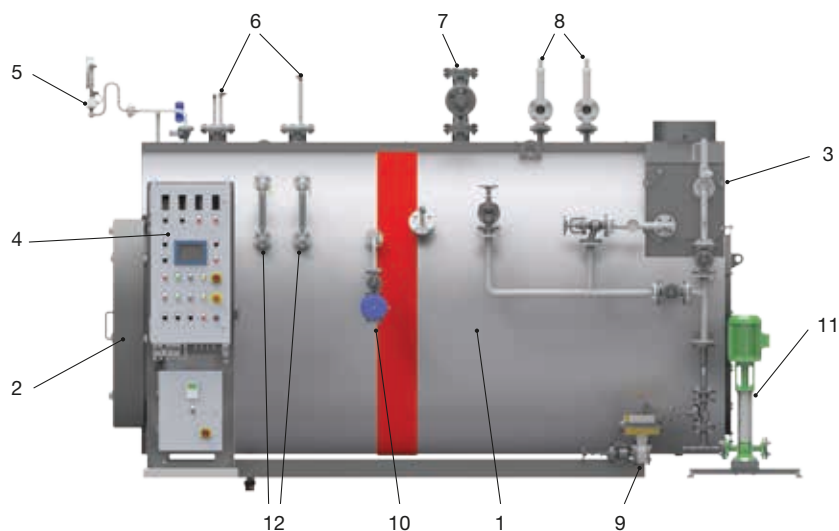

TECHNICAL DATA

Model	Steam production *	Nominal output	Nominal input STD **	Nominal input HP **	Max. working pressure	Water content at level	Total volume	ΔP smoke side	Burner head min. length
	kg/h	kW	kW	kW	bar	l	l	mbar	mm
500	500	341	379	359	12	1205	1800	3	350
800	800	547	608	576	12	1240	1950	4.2	350
1000	1000	682	758	718	12	2115	3200	5.5	350
1250	1250	853	948	898	12	2500	3550	6	350
1500	1500	1023	1137	1077	12	2850	3950	6.2	350
1750	1750	1194	1327	1257	12	3020	4100	6.5	350
2000	2000	1364	1516	1436	12	3150	4200	6.8	350
2500	2500	1705	1895	1795	12	3345	4325	7.5	350
3000	3000	2046	2273	2154	12	4550	5660	10.5	350
3500	3500	2387	2652	2513	12	4600	6200	9	350
4000	4000	2728	3031	2872	12	4950	6750	11	350

*with feeding water temperature = 80°C ** According working pressure and load conditions

PRODUCT PLUS VALUES

- **Low NO_x EMISSION < 80mg/kWh**
because of 3 pass and Low NO_x burner (on request)
- **FRONT AND REAR DOORS**
for easy cleaning and inspection
- **HIGH EFFICIENCY**
thanks to the 3 pass design and the possibility to install economizers (optional)
- **CONTROL PANEL**
either electromechanic or electronic (PLC) with optional expansion kits
- **24/72 HOUR UNATTENDED OPERATIONAL**
by the means of specific equipment

TYPE OF PIPES

SMOOTH PIPES

The smooth smoke pipes, suitable for gas, light and heavy oil operation, constituting the tube bundle, increase the thermal exchange and allow the removal of the residual combustion products.

They are formed by pipes with, inside, helical turbulators. They are standard supplied for gas, light and heavy oil operation.

Efficiency up to 90%.

In function of working pressure of the boiler.



ESALU PIPES

The ESALU smoke pipes (UNICAL patent), suitable for gas, constituting the tube bundle, allow to reach a very high thermal exchange. They are formed by pipes with, inside, special inserts of different types and shapes. The adoption of the ESALU pipes allowed to reach high performances in terms of efficiency, with important reduction in terms of running costs, fuel consumption and polluting emissions. They are standard supplied for gas operation.

Efficiency up to 94%.

In function of working pressure of the boiler.



BREVETTO
Unical
PATENT

DIMENSIONS

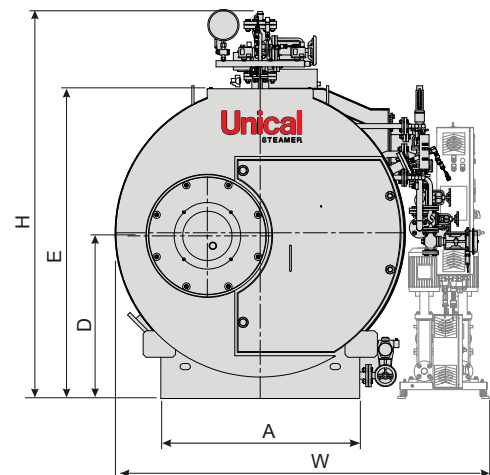
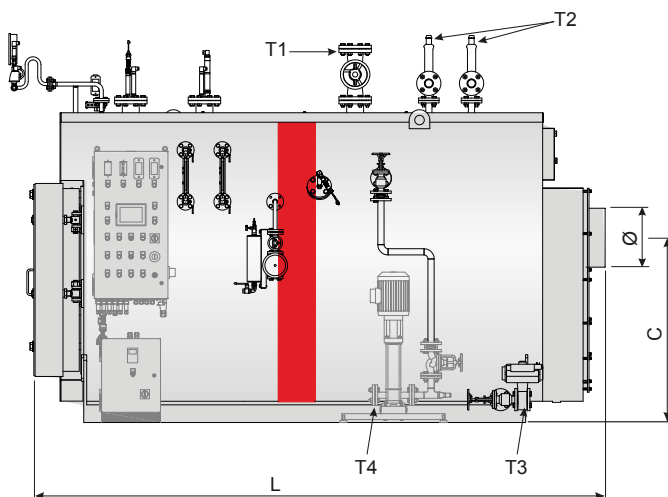

Model	W	L	H	A	C	D	E	Ø	T1	T2	T3	T4	Empty weight	Total weight
	mm	mm	mm	mm	mm	mm	mm	mm	DN	DN	DN	DN	kg	kg
500	2050	2600	2250	1000	1120	925	1750	258	40	40	25	25	2600	3805
800	2050	2800	2250	1000	1120	925	1750	358	50	40	25	25	3000	4240
1000	2350	3000	2500	1200	1220	1025	1950	358	50	40	25	25	3450	5565
1250	2350	3200	2500	1200	1220	1025	1950	408	65	40	25	25	3700	6200
1500	2350	3350	2500	1200	1220	1025	1950	408	65	40	25	25	4200	7050
1750	2500	3500	2650	1350	1350	1100	2100	408	65	40	40	40	4800	7820
2000	2500	3650	2650	1350	1350	1100	2100	408	80	40	40	40	5200	8350
2500	2500	3800	2650	1350	1350	1100	2100	508	100	40	40	40	6200	9545
3000	2500	4150	2650	1350	1350	1100	2100	508	100	40	40	40	7000	11550
3500	2750	4500	2900	1600	1500	1225	2350	608	125	50	40	40	7300	11900
4000	2750	4800	2900	1600	1500	1225	2350	608	125	50	40	40	7950	12900