

BAHR'12

INSTRUCTIONS ON INSTALLATION, USE AND MAINTENANCE

DATA PLATE

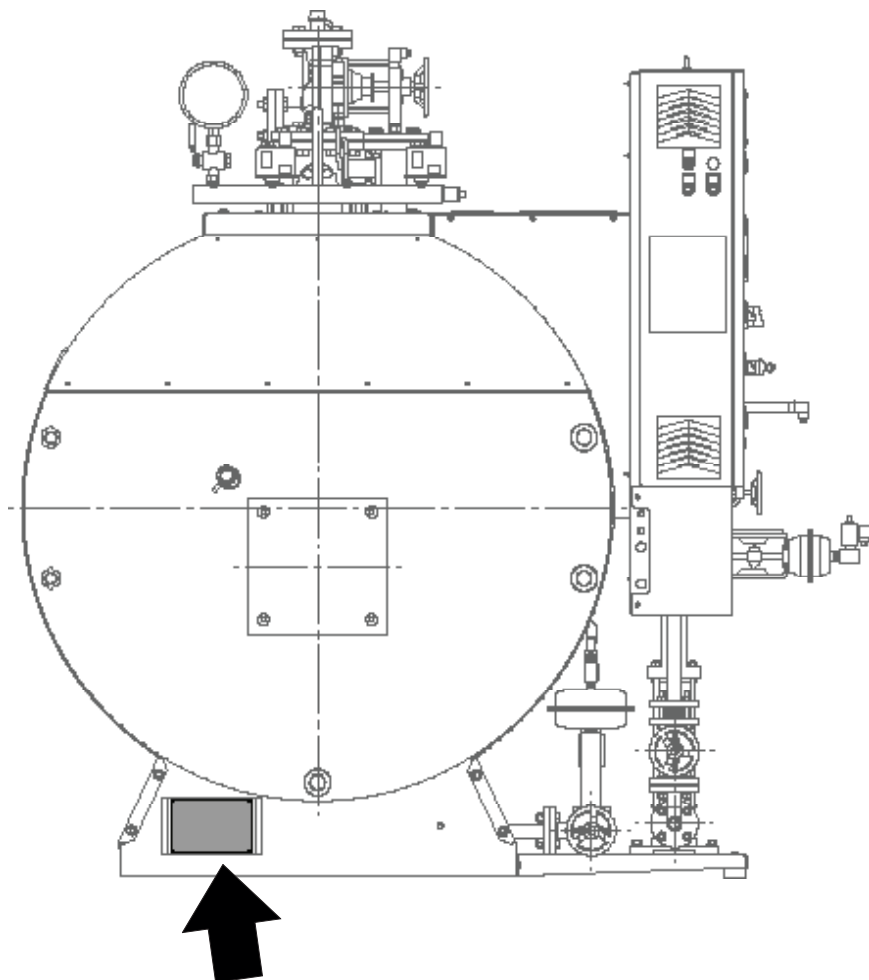

| | | | |
|--|------------------------------|--|--|
| Unical STEAMER | | CE 1370 | |
| Modello Model | | Pressione max. ammiss. PS (bar) Max. Design Pressure | |
| Numero di Fabbrica Serial Number | | Pressione max. di esercizio (bar) Max. Working Pressure | |
| Anno di Fabbricazione Manufacturing Year | | Temperatura max. ammiss. TSmax (°C) Max. Allowable Temperature | |
| Potenza Nominale (kW) Heat Output | | Temperatura max. di esercizio (°C) Max. Working Temperature | |
| Potenza Termica al focolare (kW) Heat Input | | Temperatura min. ammiss. TSmin (°C) Max Allowable Temperature | |
| Fluido Fluid | Acqua Water | Pressione di prova idrostatica (bar) Hydraulic Test Pressure | |
| Produzione vapore (kg/h) Steam Capacity | | Data di prova idrostatica Hydraulic Test Date | |
| Superficie riscaldata (m²) Heating Surface | | Massa di riempimento max. (kg) Max. Filling mass | |
| Volume Totale V (l) Total Volume | | Tara (kg) Tare | |
| Unical AG S.P.A. Via Roma, 123 - 46033 Castel d'Ario - Mantova - Italy | | | |

| | |
|--------------------------------------|----------|
| 1 GENERAL INFORMATION | 4 |
| 1.1 General warnings | 4 |
| 1.2 Symbols used in the manual | 5 |
| 1.3 Safety warnings | 5 |

| | |
|--|----------|
| 2 TECHNICAL FEATURES AND DIMENSIONS | 7 |
| 2.1 General description of the range 7 | |
| 2.2 Description of components | 8 |
| 2.3 General features | 9 |
| 2.4 Dimensions | 10 |
| 2.5 Operation data | 12 |

| | | |
|---|-----------|---|
| 3 INSTALLATION INSTRUCTIONS | 13 | |
| 3.1 General warnings | 13 | |
| 3.2 Installation standards | 13 | |
| 3.3 Supply conditions | 14 | |
| 3.4 Handling | 14 | |
| 3.5 Positioning in boiler room | 15 | |
| 3.6 Water features | 16 | |
| 3.7 Hydraulic connections | 19 | |
| 3.8 Pneumatic connection | 19 | |
| 3.9 Gas connection | 20 | |
| 3.9 Condensation drainage | 23 | |
| 3.11 Connection to the flue | 21 | |
| 3.12 Burner assembly | 22 | |
| 3.13 Furnace door: adjustment, opening, closing | 23 | |
| 3.14 Electrical connections | 24 | |
| 3.15 Control panels | 25 | |
| 3.16 Commissioning | 28 | |
| | | 3.17 Subsequent start-ups and operation |
| | | 3.18 Instructions for stopping the generator |
| | | 3.19 Instructions for the emergency stop of the generator |
| | | 3.20 Instructions for decommissioning and storage |

| | |
|--|-----------|
| 4 INSPECTIONS AND MAINTENANCE | 38 |
| 4.1 General rules for running steam generators | 38 |
| 4.2 Maintenance instructions | 39 |
| 4.3 General rules for decommissioning | 39 |
| Operating anomalies | 40 |
| Residual risks from Risks Analysis pursuant to the European Directive 97/23/EC - PED | 42 |

1

GENERAL INFORMATION

1.1- GENERAL WARNINGS

This document is the Technical Manual for installation, use and maintenance of BAHR '12 type high pressure flame blowing steam generators.

BAHR'12 steam generators (with the exception of those fitted with Basic electrical panels) are equipped to "Operate without continuous supervision" by a person authorised to run it up to a maximum of 24/72 hr.

The BAHR '12 type steam generator is manufactured, tested and certified as SET in compliance with the Essential Safety Requirements of Directive 97/23/EC "PED - Pressure Equipment Directive" according to the B+F conformity assessment modules.



ATTENTION!

The BAHR '12 series steam generators must be operated within the limits for which they were designed; any other use must be considered improper and therefore dangerous.

These design limits are given:

- on the data plate applied on the appliance;
- on the declaration of conformity supplied with the generator.



ATTENTION!

This manual is an integral and essential part of the supply and must be delivered to the user.

In the event that the generator is transferred in use or sold to other Users (change of destination or move) make sure that the appliance is transferred together with this installation, use and maintenance manual so that it can be consulted by the entrusted installer, the maintenance technician and the new owner.

Before starting installation, starting the ignition process or undertaking any maintenance, carefully read the instructions and procedures contained in this manual; they provide important information regarding the safety of the system and the safety of persons.

The installation, operation and maintenance must be carried out in compliance with the regulations in force, following the instructions described in this manual; also, any operation must be carried out by professionally qualified and authorised personnel.



ATTENTION!

THE RUNNING OF THE STEAM GENERATOR MUST BE ASSIGNED TO QUALIFIED PERSONNEL AS DEFINED BY ITALIAN LEGISLATIVE DECREE 1 MARCH 1974



IT IS STRICTLY FORBIDDEN FOR PERSONS NOT SPECIFICALLY ENABLED TO USE, RUN, MAINTENANCE THE GENERATOR.



ATTENTION!

Incorrect installation, inadequate use and maintenance of the appliance can cause damage to persons or property, for which the MANUFACTURER is not liable.



CAREFULLY READ AND FOLLOW THE INSTRUCTIONS CONTAINED IN THIS MANUAL BEFORE CARRYING OUT ANY OPERATION



ATTENTION!

THE GENERATOR IS NOT DESIGNED TO BE INSTALLED OUTDOORS, BUT MUST BE LOCATED WITHIN THE APPROPRIATE PREMISES (BOILER ROOM). OUTDOOR OPERATION CAN DAMAGE THE SET, THUS RESULTING IN SERIOUS DANGER DUE TO:

- collapse / burst of framework aimed at the pressure containment for embrittlement of the metal parts of the framework making up the pressurised body;
- collapse/burst for failed operation/inhibition of the safety and adjustment accessories;
- damage due to impairment of safety equipment / adjustment due to the action of rainwater;
- minimum temperature not compatible with the minimum allowable for the set/components, during the expected life.
- impairment of the IP protection of electrical parts not suitable for operating the set outdoors under the action of atmospheric agents.



ATTENTION!

PURSUANT TO THE LEGISLATION IN FORCE IT IS NOT PERMITTED TO OPERATE THIS GENERATOR BEFORE YOU HAVE COMMUNICATED COMMISSIONING TO THE NATIONAL CONTROL BODIES AS PRESCRIBED IN "DECREE 1 December 2004, no. 329, Regulation with standards for the commissioning and use of pressure equipment and assemblies referred to in article 19 of the Legislative Decree 25 February 2000, no. 93" to which the equipment User must strictly adhere because RESPONSIBILITY of the same.



The generator is excluded from commissioning verification as it meets art. 5, paragraph d) of the Italian Ministerial Decree. 1 December 2004 No. 329; However, the user **MUST COMMUNICATE COMMISSIONING TO THE LOCAL COMPETENT AUTHORITIES AS SET OUT IN ART. 6 OF THE SAME:**

The user has the obligation to communicate the commissioning together with INAIL (formerly ISPESEL) and competent ASL in

the territory, as defined in art. 6 of Italian Ministerial Decree of 1 December 2004 No. 329

- The user has the obligation to submit the steam generator to the periodic inspections of law provided for by the Italian Ministerial Decree of 1 December 2004 No. 329.

as foreseen by Annex B Table:

- Internal visit and operation verification every 2 years
- Integrity check every 10 years

1.2 - SYMBOLS USED IN THE MANUAL

Pay special attention when reading this manual to the parts marked by the symbols:



DANGER!
Serious danger for personal safety and life



ATTENTION!
Possible dangerous situation for the product and the environment



NOTE!
Tips for the user

1.3 - SAFETY WARNINGS

Please strictly adhere to the safety warnings to avoid danger and damage to people and property.

Addressees

The following instructions are intended exclusively for specialised personnel.

- Interventions on the gas system must only be carried out by qualified installers in accordance with the law and authorised by the relevant gas company.
- The interventions to the electrical system must only be carried out by specialised and qualified personnel, according to the law.
- Commissioning must be done by professionally qualified personnel.

Standards

In case of intervention, follow:

- the accident-prevention regulations,
- the environmental protection standards,
- the operating safety standards,
- the provisions of the Insurance Institute against accidents at work
- Directive 97/23/EC.

Behaviour in case of fuel leaks



Danger
The leaking of fuel can cause explosions and serious injuries.

- Do not smoke!
Avoid naked flames and sparks. Never activate lights or electrical devices.

- Close the shut-off valve on the fuel supply line.
- Open doors and windows.
- Evacuate people from the dangerous area.
- Inform the gas and electricity company from outside the building.
- Shut-off electric power supply from a safe position (from outside the building).

Behaviour in case exhaust gas leaks



Danger
The exhaust gas can cause fatal intoxication.

- Switch off the system.
- Ventilate the place of installation.

Interventions on the system

- Close the fuel shut-off valve and make sure that it cannot be opened accidentally.
- Disconnect the system supply voltage (e.g. acting on the individual switch or on the main switch) and make sure that voltage is disconnected.
- Make sure that it cannot be switched on again.



Attention
Any electrostatic discharges may damage the electronic components.
Before carrying out the works, discharge the electrostatic charge to the ground.

Hot surfaces



Risk of burns caused by contact with hot surfaces:

- steam pipe,
- hot water pipe,
- manhole inspection cover,
- front door and smoke chamber, could become hot.

Comply with the safety standards at work!

Repairs



Attention

It is not allowed to carry out repair work on parts with technical safety function. Replace the faulty parts with original Unical spare parts only.

Additional components, spare parts and parts subject to wear



Attention

Spare parts and pieces subject to wear that were not tested with the system can jeopardise its operation. The installation of parts not approved and unauthorised modifications may compromise safety and affect the warranty rights. For the replacement, only use original Unical spare parts.

Draining boiling water



Attention

Purge and desalination water can reach temperatures of 100°C and more. Before being conveyed to the drainage system, it must be cooled to a temperature of < 35°C.

Draining condensate produced by combustion gases



Attention

Upon operating of the boiler system, or under certain operating conditions, condensation may form in the smoke passes and in the smoke chamber.

The system installer must provide a suitable type of installation that allows the safe discharge of condensate water.

The produced condensate water must be neutralised in compliance with the standards in force.

Safety Guidelines

If there is a risk of imminent damage, decommission the boiler immediately.

In case of serious damage to the boiler or to the water supply tanks, immediately inform the authorised inspection body before carrying out repairs.

Comply with the technical instructions.

An official authorisation is required to install and operate the steam generators that must be available before start-up.

In the event of explosion, the system user is obliged to immediately report to the authorised inspection body, regardless of whether people have been injured or not. In the event of damage, do not change the created state, before the authorised inspection body has carried out a check, unless this constitutes a preventive measure to avoid further damage and to safeguard the safety of people.

Access to the boiler room is forbidden to unauthorised personnel.

Keep the boiler room clean, well lit and, above all, free from foreign objects that obstruct the operation.

During operation, keep the prescribed exits open and free.

The service personnel is responsible for recording all events, such as:

- faults,
- new settings,
- use of spare parts,
- repairs.

The routine readings of the operating equipment must also be recorded.

Immediately report any visibly phenomena on welding seams, not-hermetic damaged points or with first signs of rust, unusual behaviour of the operating equipment and system components, anomalous noises inside the boiler.

System faults and defects that cannot be eliminated must be equally reported to the manufacturer.

All boiler components and adjustment devices must be protected against rain, water and steam leaks. Any damage or leaks must be immediately repaired.

TECHNICAL FEATURES AND DIMENSIONS

2.1 - GENERAL DESCRIPTION OF THE RANGE

The series of high pressure steam generators, with smoke pipes, with flame blowing furnace, high performing BAHR'12 Unical STEAMER is designed for a maximum allowable pressure PS = 12 bar.

The range includes no. 15 models with a steam production of 300 kg / h (nominal power = 204 kW) at 6000 kg / h (nominal power = 4089 kW).

The BAHR '12 range of generators is made up of the following versions:

- OR** suitable for operation with gas burners, gas oil or fuel oil
- STD** suitable for operation with gas burners, gas oil or fuel oil
- HPO** suitable for operation with gas burners, gas oil
- HP** suitable for operation with gas burners

EC To further improve the already high value performance of the generator, without influencing the sizes, the BAHR'12 STD, HPO and HP models are already provided for mounting, on request, (already in the factory or at a later time), the EC economiser composed of:

- a finned pipe carbon steel exchange coil, which can be easily inserted into the rear smoke chamber (drawer insertion);
- a modulating or inverter supply valve
- electrical components;
- processing pipes.

The EC kit is specific for each model and requires, in combination, the water level modulation unit.

The single-block version generator supplied is composed of the following units:

A) Boiler body complete with:

- manhole,
- front door full with flame warning light and blind plate for connection to burner,
- smoke chamber complete with inspection door and cleaning and flue outlet fitting,
- rock wool insulation coating and pre-painted aluminium casing.

B) Finishing assembly consisting of:

- steam line flow valve as main steam outlet
- 2 spring safety valves
- blind flange on the secondary steam outlet

C) Assembly control panel

on request the generator can be equipped with 3 different types of control panel (BASIC, BMI or IML) and relative accessories connected to them (that can be connected).

BASIC control board composed of:

- BASIC control panel including wiring (pressure gauges, probes, burner power),
- no.4 level probes (min, max, safety)
- no. 2 probe holder flanges,
- no. 2 level indicators,
- manifold with pressure gauge, 3 way valve, pressure switches (2 control + 1 safety)

BMI control board composed of:

- BMI control panel including wiring (pressure gauges, probes, burner power),
- no.4 level probes (min, max, safety),
- no. 2 probe holder flanges,
- no. 2 level indicators,
- manifold with pressure gauge, 3 way valve, pressure switches (2 control + 1 safety)

IML control board composed of:

- IML control panel including wiring (pressure switches, level gauges, probes, burner power),
- no. 3 level probes (2 safety, 1 set),
- barrel with capacitive probe
- no. 2 probe holder flanges,
- no. 1 level indicator,
- manifold with pressure gauge, 3 way valve, pressure switches (1 control + 1 safety), pressure transducer.

D) Supply unit

on request the generator can be equipped with 1 or 2 pumps.

1 pump unit composed of:

- shut-off valve + check valve,
- 1 pump complete with wiring,
- support base

2 pumps unit composed of:

- 2 shut-off valves + check valve,
- 2 pumps complete with wiring,
- support base

E) Boiler drain unit

on request the generator can be equipped with automatic discharge.

F) Salinity control unit (TDS)

on request the generator can be equipped with the TDS 1 or TDS2 salinity control unit.

The salinity control unit is composed of:

- shut-off valve
- relief valve
- conductivity probe (CP30 x TDS 1 - CP32 x TDS 2)
- solenoid valve
- wiring connections

G) Water level modulation unit

on request the generator can be equipped with water level modulation unit for systems with:

- 1 or 2 pumps



NOTE:

Normally, the generators are supplied fully assembled. In particular cases, to avoid damage during transportation or handling, some units are supplied unassembled.

For the reassembly, refer to the instructions supplied together with the documentation supplied with the device.

2.2. - DESCRIPTION OF THE COMPONENTS

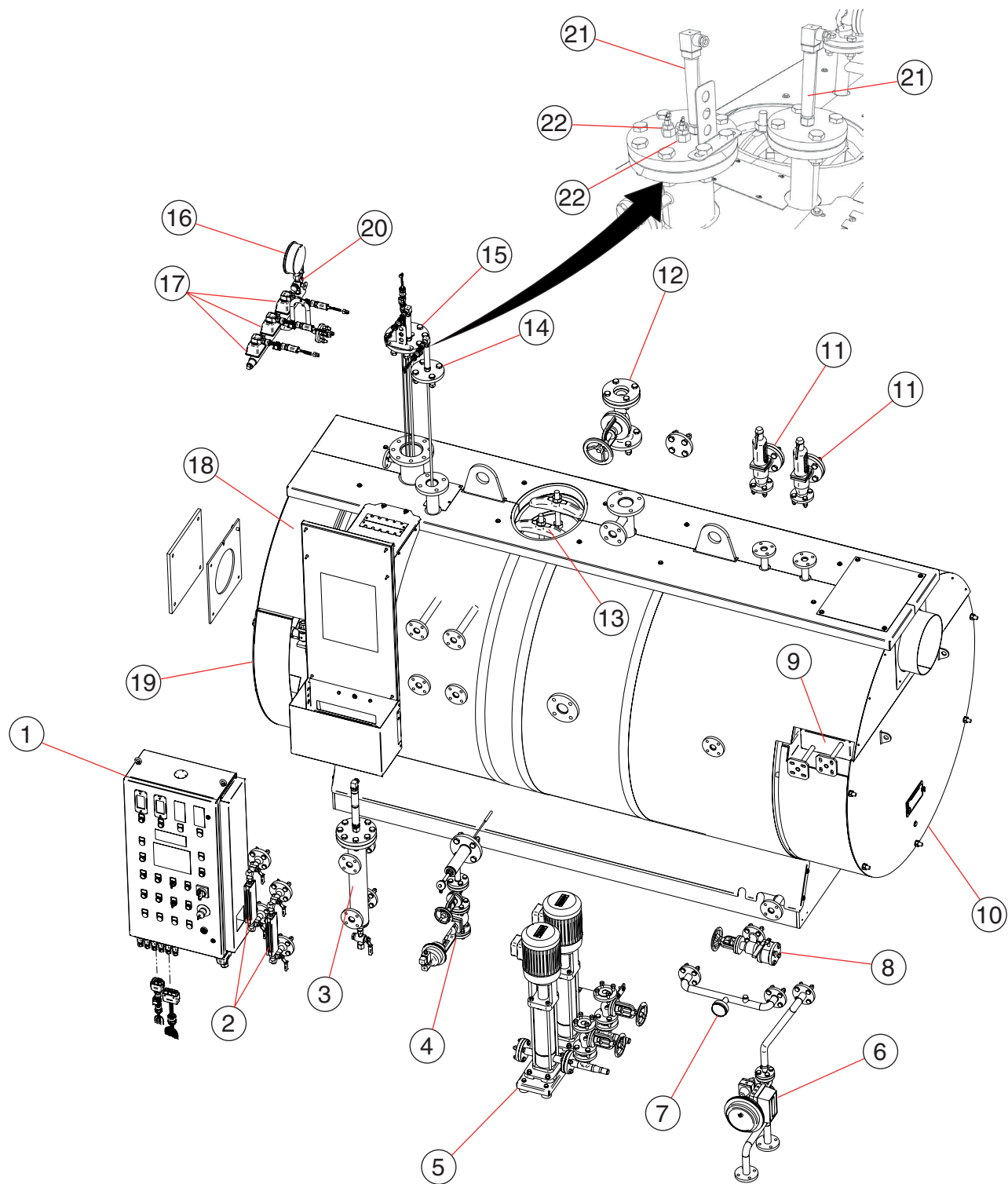

- 1 Control board
- 2 Level indicator
- 3 Capacity probe unit (optional - only with IML)
- 4 Salinity control unit (TDS)
- 5 Supply pump(s) unit
- 6 Flow regulation pneumatic valve (optional)
- 7 Thermometer (optional)
- 8 Drain valve
- 9 Economiser (optional)
- 10 Smoke chamber
- 11 Safety valve

- 12 Steam intake valve
- 13 Manhole
- 14 Probe holder flange
- 15 Probe holder flange
- 16 Pressure gauge
- 17 Pressure switch
- 18 Insulating coating
- 19 Front door
- 20 Three-way valve
- 21 Safety probe
- 22 Level probe

2.3 - GENERAL FEATURES

The flame blowing generator is composed by cylindrical hearth with wet end in which the flame develops and where the reversal of the combustion products occurs.

The fumes, therefore, enter the tube bundle at the front tube plate and are conveyed towards the rear smoke chamber from which they escape through the chimney fitting.

The appliance is dimensioned to ensure low thermal loads in the combustion chamber and a low surface loading.

Construction features

Boiler body

The boiler body is made up of a cylindrical shell, hearth, hearth bottom and flat steel piping plates, sized according to the VSG calculation code (Generators Stability Verification) (and CTI recommendations) and in compliance with the technical standards in force.

The materials used are accompanied by manufacturing certificates attesting the chemical and mechanical features and inspections during the production cycle and therefore their suitability to use.

The welded joints are performed at electric arc according to approved procedures by properly qualified personnel and subjected, according to an internal level of "Manufacture and Control", to Non Destructive Testing.

The smoke pipes that make up the tube bundle, are welded to the piping plates by means of qualified automatic procedures. When production is finished, any pressurised body is tested by carrying out the hydraulic test in compliance with laws / standards in force.

Front door

The front door is made of welded steel sheet, coated internally with a layer of insulating material (towards the outside) and a layer of refractory material (towards the inside). It is mounted on hinges that allow opening reversibility and complete adjustment. It is equipped with self-cleaning flame-warning light, suitably positioned to control the correctness of combustion in opera-

tion; on the same is bolted the burner coupling plate, supplied blind, can be prepared for the type of burner indicated by the customer.

Rear smoke chamber

The smoke chamber, made of welded steel sheet and insulated with rock wool, is fixed to the rear tube plate by bolts to allow its removal. It is equipped with suitable cleaning door and smoke connection with horizontal axis of suitable diameter to the power of the generator.

Base and walking surface covering

The base is constituted by a frame made of steel profiles electro-welded to the tube plates and closed by means of welded steel plate.

The service walkway located at the top of the generator is also composed of a steel profile frame, covered with chequered sheet metal (walking surface covering) and, when required, completed with a parapet with handrail.

Insulation of the planking and gables

The thermal insulation of the planking is obtained with rock wool mattress, linked with thermosetting resins, suitably supported and coated on the outside by the pre-painted aluminium case.

The device gables (steam rooms) are also insulated with rock wool, externally encased. Particular attention has been paid to the drastic reduction of thermal bridges, through the interposition of felts and insulating gaskets in order to prevent body contact with the coating, so as to reduce the surface temperatures and limit dispersions to the benefit of both safety and yield.

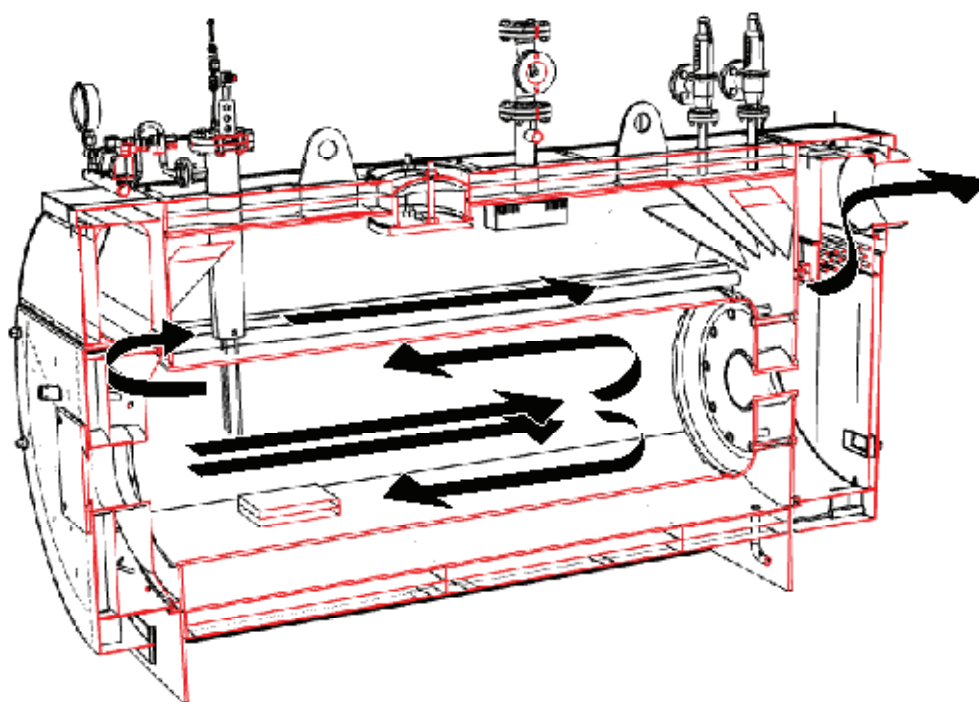

2.4 - DIMENSIONS

BAHR'12 OR

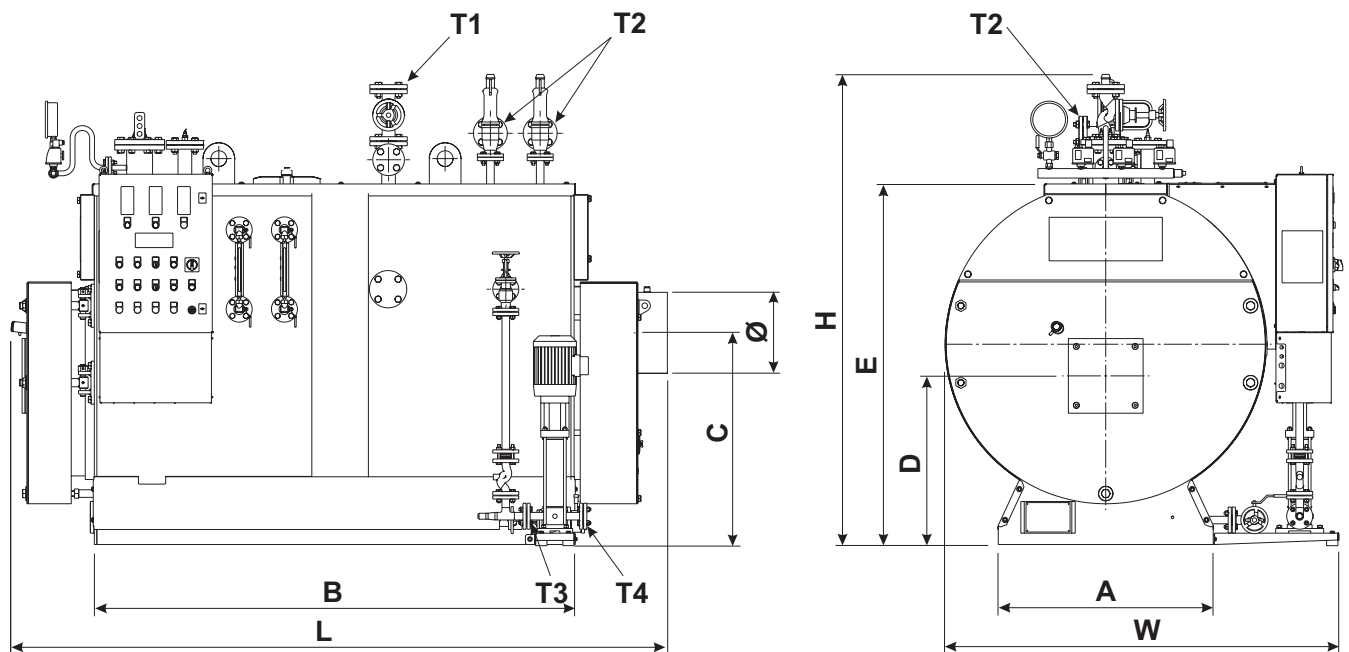

- T1 Steam inlet
- T2 Safety valve drain
- T3 Water supply
- T4 Boiler drain

| BAHR' 12 | W | L | H | A | B | C | D | E | Ø | T1 | T2 | T3 | T4 | Weight empty kg | Weight in oper. kg |
|-------------|------|------|------|------|------|------|------|------|-----|-------|------|------|------|--------------------|-----------------------|
| Model | mm | mm | mm | mm | mm | mm | mm | mm | mm | | | | | | |
| 300 | 1474 | 2320 | 1820 | 780 | 1550 | 815 | 635 | 1333 | 219 | DN32 | DN40 | DN25 | DN25 | 1620 | 2145 |
| 400 | 1474 | 2320 | 1820 | 780 | 1550 | 815 | 635 | 1333 | 219 | DN32 | DN40 | DN25 | DN25 | 1620 | 2145 |
| 500 | 1861 | 2530 | 1940 | 860 | 1750 | 880 | 695 | 1453 | 258 | DN40 | DN40 | DN25 | DN25 | 2010 | 2770 |
| 600 | 1861 | 2530 | 1940 | 860 | 1750 | 880 | 695 | 1453 | 258 | DN40 | DN40 | DN25 | DN25 | 2010 | 2770 |
| 800 | 1996 | 2900 | 2077 | 950 | 2120 | 935 | 745 | 1593 | 358 | DN50 | DN40 | DN25 | DN25 | 2830 | 3910 |
| 1000 | 1996 | 2900 | 2077 | 950 | 2120 | 935 | 745 | 1593 | 358 | DN50 | DN40 | DN25 | DN25 | 2830 | 3910 |
| 1250 | 2126 | 3259 | 2294 | 1090 | 2526 | 1015 | 860 | 1783 | 408 | DN65 | DN40 | DN25 | DN25 | 3710 | 5265 |
| 1500 | 2126 | 3259 | 2294 | 1090 | 2526 | 1015 | 860 | 1783 | 408 | DN65 | DN40 | DN25 | DN25 | 3710 | 5265 |
| 1750 | 2246 | 3559 | 2422 | 1200 | 2750 | 1170 | 905 | 1918 | 408 | DN65 | DN40 | DN25 | DN40 | 4610 | 6615 |
| 2000 | 2246 | 3559 | 2422 | 1200 | 2750 | 1170 | 905 | 1918 | 408 | DN65 | DN40 | DN25 | DN40 | 4610 | 6615 |
| 2500 | 2296 | 3640 | 2774 | 1470 | 2830 | 1405 | 1080 | 2243 | 508 | DN80 | DN40 | DN32 | DN40 | 6560 | 9450 |
| 3000 | 2296 | 3640 | 2774 | 1470 | 2830 | 1405 | 1080 | 2243 | 508 | DN80 | DN40 | DN32 | DN40 | 6560 | 9450 |
| 4000 | 2756 | 4107 | 3031 | 1700 | 3300 | 1500 | 1170 | 2473 | 608 | DN100 | DN40 | DN32 | DN40 | 8980 | 13135 |
| 5000 | 2856 | 4590 | 3173 | 1800 | 3800 | 1525 | 1195 | 2548 | 658 | DN125 | DN50 | DN32 | DN40 | 10540 | 16340 |
| 6000 | 3026 | 4810 | 3315 | 1850 | 4003 | 1600 | 1210 | 2618 | 658 | DN150 | DN50 | DN40 | DN40 | 11750 | 18510 |

BAHR'12 STD - EC - HP - HPEC - HPO - HPOEC

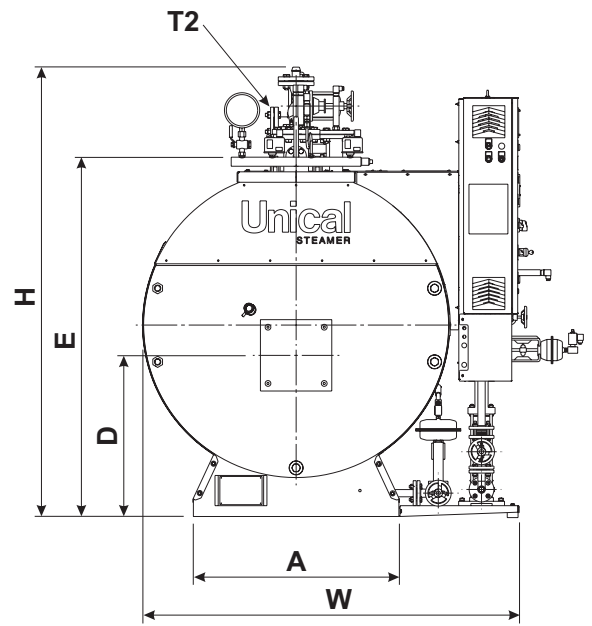
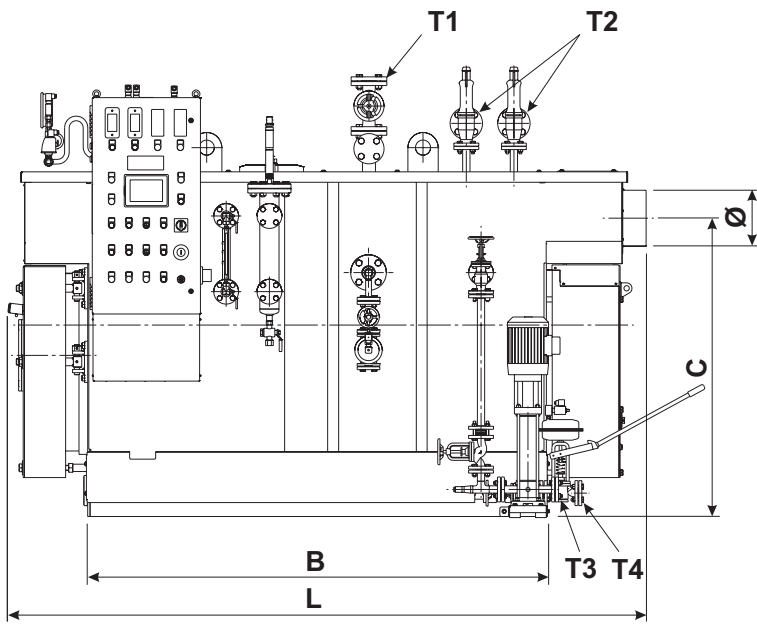

- T1 Steam inlet
- T2 Safety valve drain
- T3 Water supply
- T4 Boiler drain

Technical features

| BAHR' 12 Model | W mm | L mm | H mm | A mm | B mm | C mm | D mm | E mm | Ø mm | T1 | T2 | T3 | T4 | Weight empty kg | Weight in oper. kg |
|----------------|------|------|------|------|------|------|------|------|------|-------|------|------|------|-----------------|--------------------|
| 300 | 1474 | 2340 | 1820 | 780 | 1550 | 1167 | 635 | 1333 | 219 | DN32 | DN40 | DN25 | DN25 | 1650 | 2175 |
| 400 | 1474 | 2340 | 1820 | 780 | 1550 | 1167 | 635 | 1333 | 219 | DN32 | DN40 | DN25 | DN25 | 1650 | 2175 |
| 500 | 1861 | 2565 | 1940 | 860 | 1750 | 1266 | 685 | 1453 | 219 | DN40 | DN40 | DN25 | DN25 | 2040 | 2800 |
| 600 | 1861 | 2565 | 1940 | 860 | 1750 | 1266 | 685 | 1453 | 219 | DN40 | DN40 | DN25 | DN25 | 2040 | 2800 |
| 800 | 1996 | 2950 | 2077 | 950 | 2120 | 1349 | 745 | 1593 | 258 | DN50 | DN40 | DN25 | DN25 | 2860 | 3940 |
| 1000 | 1996 | 2950 | 2077 | 950 | 2120 | 1379 | 745 | 1593 | 258 | DN50 | DN40 | DN25 | DN25 | 2860 | 3940 |
| 1250 | 2126 | 3414 | 2294 | 1090 | 2526 | 1555 | 860 | 1783 | 308 | DN65 | DN40 | DN25 | DN25 | 3750 | 5305 |
| 1500 | 2126 | 3414 | 2294 | 1090 | 2526 | 1555 | 860 | 1783 | 308 | DN65 | DN40 | DN25 | DN25 | 3750 | 5305 |
| 1750 | 2246 | 3543 | 2422 | 200 | 2750 | 1685 | 905 | 1918 | 358 | DN65 | DN40 | DN25 | DN40 | 4650 | 6655 |
| 2000 | 2246 | 3543 | 2422 | 1200 | 2750 | 1685 | 905 | 1918 | 358 | DN65 | DN40 | DN25 | DN40 | 4650 | 6655 |
| 2500 | 2296 | 3860 | 2774 | 1470 | 2830 | 2004 | 1080 | 2243 | 408 | DN80 | DN40 | DN32 | DN40 | 6600 | 9490 |
| 3000 | 2296 | 3860 | 2774 | 1470 | 2830 | 2004 | 1080 | 2243 | 408 | DN80 | DN40 | DN32 | DN40 | 6600 | 9490 |
| 4000 | 2756 | 4360 | 3031 | 1700 | 3300 | 2187 | 1170 | 2473 | 458 | DN100 | DN40 | DN32 | DN40 | 9030 | 13185 |
| 5000 | 2856 | 4943 | 3173 | 1800 | 3800 | 2261 | 1195 | 2548 | 488 | DN125 | DN50 | DN32 | DN40 | 10590 | 16390 |
| 6000 | 3026 | 5236 | 3315 | 1850 | 4003 | 2326 | 1210 | 2618 | 488 | DN150 | DN50 | DN40 | DN40 | 11800 | 18560 |

2.5 - OPERATING DATA

| Data project | U of M | BAHR '12 Model | | | | | | | | | | | | | | |
|---|--------|----------------|-------|-------|-------|-------|-------|-------|-------|-------|-------|-------|-------|-------|-------|-------|
| | | 300 | 400 | 500 | 600 | 800 | 1000 | 1250 | 1500 | 1750 | 2000 | 2500 | 3000 | 4000 | 5000 | 6000 |
| Useful power * | kW | 204 | 273 | 341 | 409 | 560 | 700 | 852 | 1022 | 1193 | 1363 | 1704 | 2045 | 2726 | 3408 | 4089 |
| Thermal output | kW | 234 | 314 | 392 | 470 | 644 | 805 | 979 | 1175 | 1371 | 1567 | 1926 | 2310 | 3133 | 3917 | 4700 |
| Steam production | kg / h | 300 | 400 | 500 | 600 | 800 | 1000 | 1250 | 1500 | 1750 | 2000 | 2500 | 3000 | 4000 | 5000 | 6000 |
| Max pressure allowable PS | bar | 12 | 12 | 12 | 12 | 12 | 12 | 12 | 12 | 12 | 12 | 12 | 12 | 12 | 12 | 12 |
| Max. Temperature allowable TS | °C | 191,7 | 191,7 | 191,7 | 191,7 | 191,7 | 191,7 | 191,7 | 191,7 | 191,7 | 191,7 | 191,7 | 191,7 | 191,7 | 191,7 | 191,7 |
| Max. Temperature working TE | °C | 191,7 | 191,7 | 191,7 | 191,7 | 191,7 | 191,7 | 191,7 | 191,7 | 191,7 | 191,7 | 191,7 | 191,7 | 191,7 | 191,7 | 191,7 |
| Volume V | L | 730 | 730 | 1030 | 1030 | 1500 | 1500 | 2195 | 2195 | 2810 | 2810 | 3950 | 3950 | 5780 | 7730 | 8600 |
| Water content at level | L | 540 | 540 | 820 | 820 | 1080 | 1080 | 1555 | 1555 | 2005 | 2005 | 2890 | 2890 | 4155 | 5800 | 6760 |
| Volume CC | m3 | 0,26 | 0,26 | 0,36 | 0,36 | 0,67 | 0,67 | 0,95 | 0,95 | 1,29 | 1,29 | 1,86 | 1,86 | 2,76 | 3,48 | 3,99 |
| Thermal Load volumetric | MW/m3 | 0,905 | 1,212 | 1,076 | 1,290 | 1,022 | 1,279 | 1,036 | 1,242 | 1,066 | 1,218 | 1,051 | 1,261 | 1,129 | 1,125 | 1,178 |
| Total area | m2 | 6,5 | 6,5 | 10,0 | 10,0 | 16,1 | 16,1 | 24,0 | 24,0 | 32,4 | 32,4 | 49,9 | 49,9 | 69,0 | 85,7 | 97 |
| Thermal Load surface | kW/m2 | 31,4 | 42,0 | 34,1 | 40,9 | 33,9 | 42,4 | 35,5 | 42,6 | 36,8 | 42,1 | 34,1 | 41,0 | 39,5 | 39,8 | 42,2 |
| Dp smoke side | mbar | 2,2 | 2,6 | 2,8 | 3,5 | 3,8 | 4,2 | 4,5 | 5,1 | 5,5 | 6,0 | 6,8 | 7,0 | 8,0 | 8,8 | 8,8 |
| Burner connection | Ø mm | 210 | 210 | 240 | 240 | 240 | 240 | 280 | 280 | 280 | 280 | 360 | 360 | 400 | 400 | 420 |
| Minimum length burner head | mm | 340 | 340 | 340 | 340 | 340 | 340 | 370 | 370 | 370 | 370 | 370 | 370 | 370 | 370 | 370 |
| Absorption max power (excluding burner) | W | 1,85 | 2,2 | 2,2 | 2,2 | 2,2 | 2,2 | 2,2 | 2,2 | 2,2 | 2,2 | 3,0 | 3,0 | 3,7 | 4,0 | 5,5 |
| Pressure of compressed air supply | bar | 4 - 6 | 4 - 6 | 4 - 6 | 4 - 6 | 4 - 6 | 4 - 6 | 4 - 6 | 4 - 6 | 4 - 6 | 4 - 6 | 4 - 6 | 4 - 6 | 4 - 6 | 4 - 6 | 4 - 6 |

INSTRUCTIONS FOR INSTALLATION

3.1 - GENERAL WARNINGS



ATTENTION!

The generator must be destined only to the use for which it has been expressly declared. Any other use is to be considered improper and therefore dangerous. This generator is used for the production of saturated steam at high pressure.



The requirements for system installation in a building always depend on the regulations in force in the country of installation.

The systems with steam generator must be installed in such a way as to facilitate use, maintenance, repair, and the monitoring of all the respective components and to ensure that personnel comply with the safety standards in the workplace.

Install the steam generator and the relative devices so that they are protected in case of shaking, oscillations and other dangers and in a way to guarantee the acoustic insulation and meet the technical requirements.

Mount the valves of the steam generator and of the relative system complete with their safety devices and discharge so that the vent and drive take place safely and that the discharge process is clearly perceptible.



Before connecting the boiler, have professionally qualified personnel:

- a) **Thoroughly wash all the system piping to remove any residues or impurities which could jeopardise the proper operation of the generator.**
- b) Check that the boiler is set up to operate with the available type of fuel.
- c) Check that the chimney / flue has an appropriate draught, without any bottlenecks, and that no exhausts from other appliances are inserted, unless the flue has been implemented to accommodate several utilities according to specific standards and prescriptions in force. Only after this check can the fitting between the boiler and chimney/flue be mounted.



ATTENTION!

The appliance must be installed by a qualified technician with the technical-professional requirements according to the law, who, under his own responsibility, guarantees compliance with standards according to good practice rules.

3.2 - INSTALLATION STANDARDS

It must be installed by a professionally qualified technician, **who shall take the responsibility of observing all local and/or national laws published in the official journal, as well as applicable technical standards.**

3.3 - TERMS OF SUPPLY

The BAHR' 12 generators are supplied in single-block.



Upon receipt, after having removed the packaging make sure the content is intact. Carry out a general inspection to verify the absence of damage due to transport, checking the conditions of the refractory of the tailgate, the presence of turbulators and their correct position inside smoke pipes (OR - STD versions).



NOTE:
Normally, the generators are supplied fully assembled. In particular cases, to avoid damage during transportation or handling, some units are supplied unassembled. For the reassembly, refer to the instructions supplied together with the documentation supplied with the generator.

3.4 - HANDLING

The BAHR'12 boilers are equipped with lifting eyebolts. Pay attention when handling the boiler and use equipment suitable for its weight.

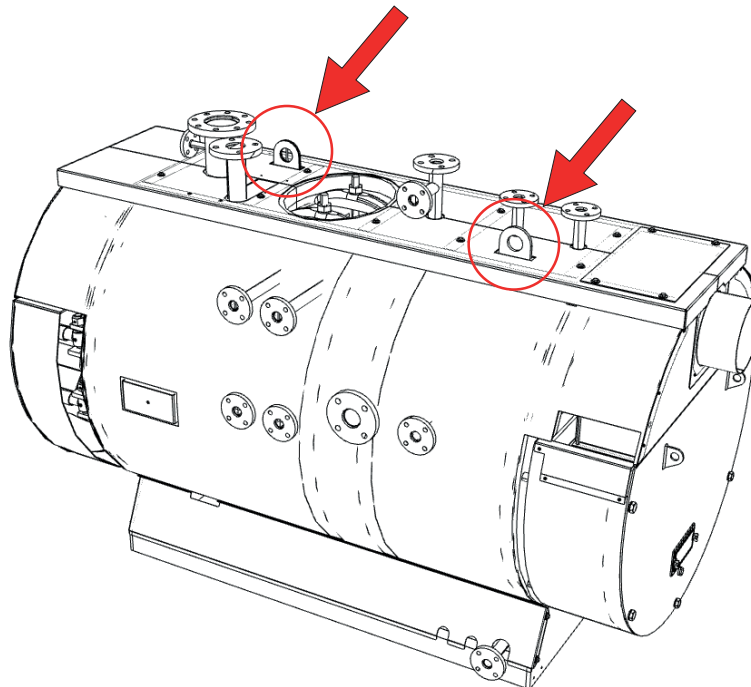

3.5 - POSITIONING IN THE BOILER ROOM

The steam generator must be installed in a place that complies with the safety requirements in force in the country of destination, with adequately dimensioned ventilation openings.

In the absence of specific provisions of the country of destination, the following indications must be complied with:

- 1) The premises must be enabled to the exclusive use of the boiler room: access must be forbidden (with visible signs) to unauthorised personnel.
- 2) Wide spaces must be set up for operation and maintenance of all system components (pumps, valves, filters, water treatment system, heat exchangers, etc.).
- 3) The support base must be raised 5 - 10 cm, in concrete, flat and able to support the weight of the generator and the relative water content.
For the dimensions of the basement, see paragraph 2.3 - DIMENSIONS (A x C parameter)
- 4) The premises must have dimensions such as to ensure the following minimum distances are net of any size:
 - a) In order to make it easier to clean the smoke circuit, there must be a free space on the front of the generator, not less than the length of the boiler body (see 2.3 - DIMENSIONS, parameter C) and, in any case, never less than 1500 mm and it must be checked that with the door opened 90°, the distance between the door and the adjacent wall is at least equal to the length of the burner.

- b) On the two sides of the generator: 0.80 m, reduced to 0.60 m if the generator is adjacent to a wall or to another generator and no accessory or control is provided in the passage.
- (*) If the steam boiler is equipped with an economiser, a clearance equal to the width of the boiler must be left, in order to allow for it to be removed easily.
- c) On the rear part of the generator: 0.80m.
- d) From the upper part of the generator: 1.80 m between the highest walking surface and the lowest obstacle of the premises cover and 1 metre between the highest point of the generator and the lowest obstacle between the generator and the cover itself. It is recommended to leave a free space at least equal to the length of the generator coil; this allows for a possible replacement.
- e) The piping and transmissions available above the generator, must be arranged so as not to hinder the work, nor obstruct the operator movement in accessing the upper part of the generator itself to visit or repair the accessories.



ATTENTION:

If the burner is powered with fuel of specific weight above that of air, the electrical parts must be placed at a height from the ground above 0.5 m.



IT IS FORBIDDEN TO INSTALL THE BOILER OUTDOORS BECAUSE IT IS NOT DESIGNED FOR THIS PURPOSE AND IT IS NOT EQUIPPED WITH AUTOMATIC ANTI-FREEZE SYSTEMS.

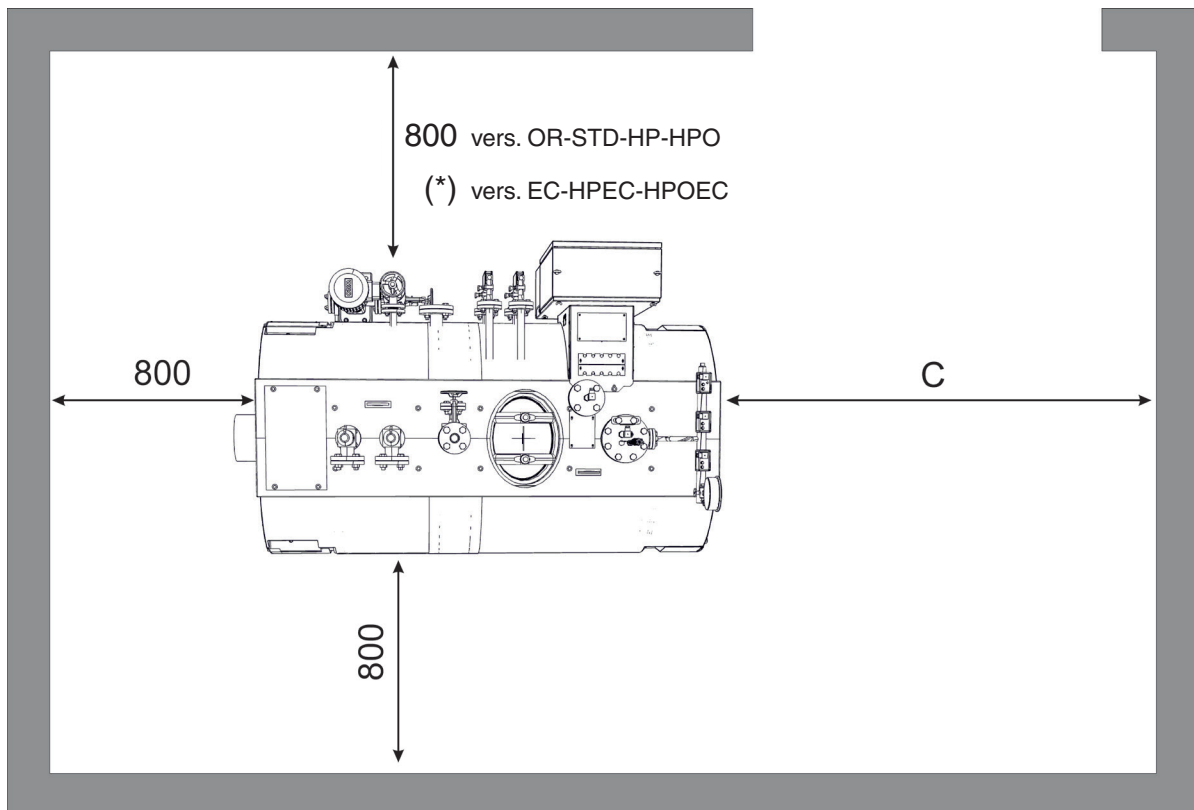

3.6 - WATER FEATURES



The generator must be fed with water of quality complying with the requirements set out in this paragraph.

It must also be ensured that the feed water and the system water cannot be polluted by harmful substances (e.g. oil, grease, sea water).

Standard of reference UNI EN 12953-10 or UNI 7550.

Most of the waters are not suitable at source for use as feed water of a steam generator. The type of feed water treatment depends on the features of the water at source. Its features vary, so regular checks of the chemical composition are required.

The water supply pipe, downstream of the chemical treatment, must be fitted with a meter in order to detect the flow rate of the top-up water added to the return condensate water; this also allows direct control of the amount of steam intake.

It is appropriate to recover as much condensate water in the supply tank as possible.

The condensate water must eventually be treated so as to meet the requirements indicated for the generator feed water (as per table 1). On the basis of these requirements, including those needed for feed water (as per table 2), it is necessary that, depending on the features at source and on the top-up flow rate, a water treatment system be installed and allow binders to be added for oxygen (possibly stabilisers for residue hardness, for alkalisation or phosphates) in the feed water tank or in its flow pipe.

These requirements should be checked by means of suitable equipment and, if possible, easy to use every 24 or 72 hours, depending on the operating mode, or according to local regulations.

Record the measured values, the top-up water flow rate, the consumption of chemicals and the necessary maintenance operations in the instruction manual, in order to be able to always go back to the operating conditions.



WARNING

Do not put water with a temperature below 60°C in the generator.

It is recommended to put feed water with an average temperature of 80°C in the generator.



ATTENTION!

Damages caused by external agents (limescale, oxygen, acid attacks, etc.) are not covered by the warranty.



Below are the quality requirements for the feed water and for the operating water according to the European Standard EN 12953-10 (tables 1-2) and indications on the frequency of the analyses (tables 3-4)

**Table 1
FEED WATER FOR STEAM GENERATORS**

| Parameters | Unit | Feed water | |
|--------------------|----------------------------|--|------------------------|
| | | | |
| Operating pressure | bar | 0.5 - 20 | > 20 |
| Appearance | | Clear, free from solid suspensions without persistent foam | |
| pH ^{a,b} | | 8.7 - 9.2 ^c | 8.7 - 9.2 ^c |
| Total hardness | ppm CaCO ₃ (°F) | < 1 (<1) | < 1 (<1) |
| Iron | ppm Fe | < 0.1 | < 0.05 |
| Copper | ppm CU | < 0.05 | < 0.03 |
| Oxygen | ppm O ₂ | < 0.05 ^d | < 0.02 ^d |
| Oils - greases | ppm | < 1 | < 1 |
| Organic substances | | Not enough to cause traces, foams or other problems | |

- a. for boilers fed with water with conductivity less than 30 pS/cm use of Na or K hydroxides is allowed only if the recommended pH range cannot be obtained with the exclusive use of sodium phosphate;
 b. for systems where there is no copper or its alloys, the feed water pH must be higher than 9.2 ;

- c. with water softened to pH > 7, it is necessary to respect the pH range indicated for boiler waters; when operating without a degasser an excess of deoxygenating agent must be guaranteed;
 d. the excess value to be guaranteed must be indicated by the supplier of the additives used for chemical conditioning.

Table 2
OPERATING WATER FOR STEAM GENERATORS

| Parameters | Unit | Conductivity of the feed water > 30 mS/cm | | Conductivity of the feed water < 30 mS/cm |
|---------------------|-----------------------|---|--------------|---|
| | | | | |
| Operating pressure | bar | 0.5 - 20 | > 20 | > 0.5 |
| Appearance | | Clear, free from solid suspensions without persistent foam | | |
| Conductivity | mS/cm | < 6000 ^b | See Figure 1 | < 1500 |
| pH | | 10.5 - 12.0 | 10.5 - 11.8 | 10.0 - 11.0 ^c |
| P alkalinity | ppm CaCO ₃ | 50 - 750 | 50 - 500 | 10 - 100 |
| M alkalinity | ppm CaCO ₃ | 100 - 1000 | 100 - 750 | 10 - 250 |
| Iron | ppm Fe | < 0.1 | < 0.1 | < 0.1 |
| Copper | ppm CU | < 0.1 | < 0.1 | < 0.1 |
| Silica | ppm SiO ₂ | See Figure 2 | | |
| Phosphate | ppm PO ₄ | 10 - 30 | 10 - 30 | 6 - 15 |
| Deoxygenating agent | ppm | Excessive deoxygenating additive according to supplier's specifications | | |
| Organic substances | | Not enough to cause traces, foams or other problems | | |

- a. excluding contribution of chemical conditioning treatments
- b. with a superheater the limit is 3000 pS/cm
- c. use alkalinisers only if the pH is less than 10; in any case, use of Na

or K hydroxides is allowed only if the recommended pH range cannot be obtained with the exclusive use of sodium phosphate.

Figure 1 (extract from the EN 12953-10 standard)
Maximum acceptable direct boiler water conductivity based on the pressure, direct feed water conductivity > 30 mS/cm

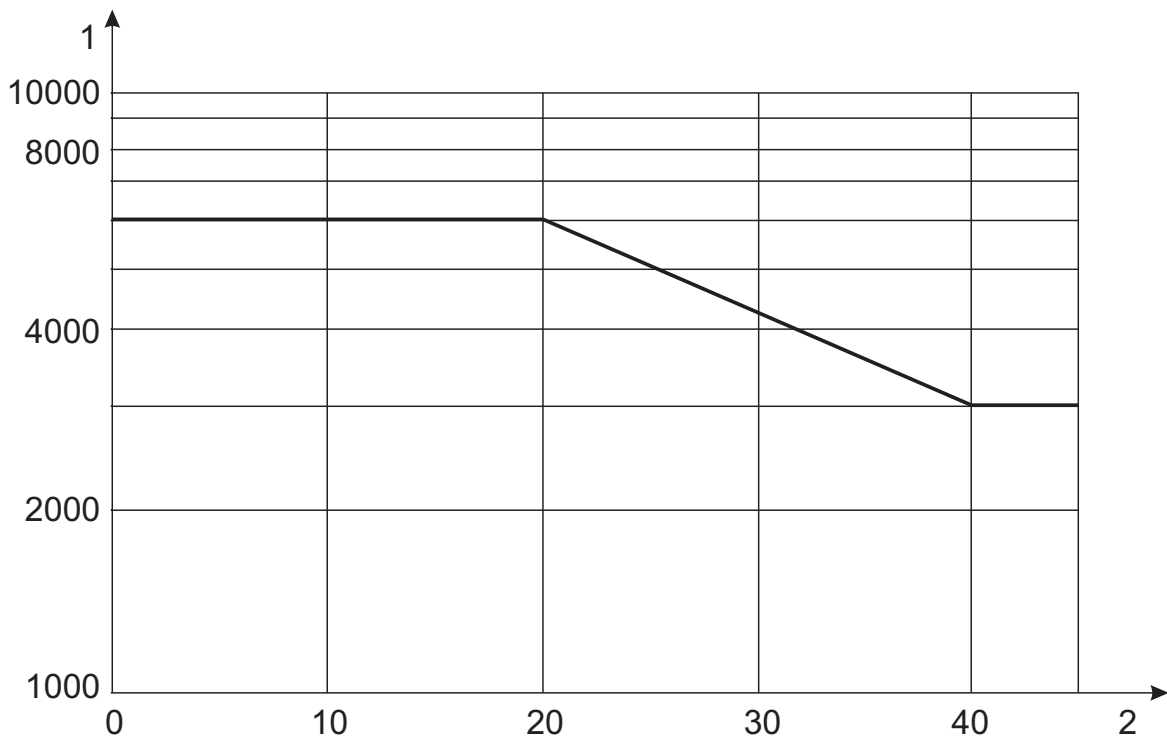

- 1 Direct conductivity mS/cm
- 2 Operating pressure in bar

FREQUENCY OF THE ANALYSES

The frequency of the analyses depends on the use of the generator and the quality of the water used; however, it is advisable to check the pH value, the total hardness and alkalinity of the feed water and operating water every two days. It is good practice, especially in variable operating conditions, to monthly subject a significant sample of the feed water and operating water to a full analysis.

It is also good practice to visually check the condensate returns for any highly polluting oily substances (reduction of evaporation on the surface of the boiler water due to a layer of oil).

**Limit values and frequencies of checks recommended according to Standard UNI - CTI 7550
FEED WATER**

| Operating pressure (bar) | | < 15 | |
|--------------------------|--------------------------|-----------|---------------|
| Parameters | Unit of measurement | Limit | Frequency (*) |
| pH value | | 7,5 - 9,5 | T - S |
| Total hardness | mg CaCO ₃ /kg | 5 | T |
| Oxygen | µg O ₂ /kg | 100 | S |
| Free carbon dioxide | µg CO ₂ /kg | 200 | S |
| Iron | µg Fe/kg | 100 | S |
| Copper | µg Cu/kg | 100 | S |
| Oily substances | mg/litro | 1 | T |
| Organic substances | mg O ₂ /kg | | |
| STD | µg/kg | | |
| Total conductivity | µS/cm | | |
| Acid conductivity | µS/cm | | |
| Silica | µg SiO ₂ /kg | | |

OPERATING WATER

| Operating pressure (bar) | | < 15 | |
|--------------------------|--------------------------|--------|---------------|
| Parameters | Unit of measurement | Limit | Frequency (*) |
| pH value | | 9 - 12 | T - S |
| Total alkalinity | mg CaCO ₃ /kg | 1000 | T |
| Total hardness | mg CaCO ₃ /kg | 5 | T |
| Total conductivity | µS/cm | 7000 | G |
| STD | mg/kg | 3500 | S |
| Silica | mg SiO ₂ /kg | 150 | S |
| Phosphates | mg PO ₄ /kg | 30 | S |
| Acid conductivity | µS/cm | | |

(*) For boilers designed to run in a regime of "Operation without continuous supervision" for up to 24/72 hours, the frequency of the tests is equal to the period of exemption.

S = Weekly, in laboratory S/2 (twice-weekly)

T = Each shift

G = Daily

| WATER PARAMETERS CHECK (DAILY) | |
|--------------------------------|-----------------------------------|
| Responsibility | System Manager / Operator |
| Record | Heating System Instruction Manual |

| WATER PARAMETERS CHECK (MONTHLY) | |
|--|-----------------------------------|
| COMPLETE QUALITY ANALYSIS OF THE BOILER AND FEED WATERS (Specialised company) | |
| Responsibility | System Manager / Operator |
| Execution | Specialised company |
| Record | Heating System Instruction Manual |

3.7 - HYDRAULIC CONNECTIONS



ATTENTION!
Before connecting the boiler to the system, thoroughly wash the pipes with a strong jet of steam, in order to eliminate metallic residue from processing and welding, oil and grease which could be present and which, reaching the boiler, could alter its functioning.

The steam generators, once positioned in the boiler room, must be connected to the following points:

- Steam outlet (T1)
- Safety valve drain (T2)
- Water supply (T3)
- Boiler drain (T4)

The sizes of the pipes for each boiler model are given in paragraph 2.3 - DIMENSIONS.

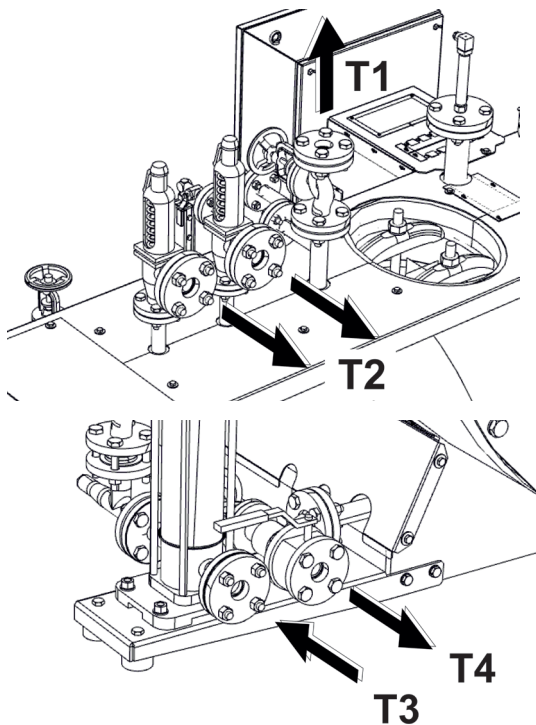

Carry out the connection of the steam line of use to the valve, making sure that the thermal expansions do not cause stresses on the same.



The drain of the safety valves must be conveyed to outside the boiler room made in such a way so as not to cause damage to people or property in case of steam discharge.

The piping diameter must not be smaller than the diameter of the safety valve drain.

To avoid stagnation of condensation, the drain pipe must be positioned with adequate slope so as to allow its complete drainage.



The pipes arriving to the appliance must be supported and arranged so as not to create dangerous efforts for the stability of the connections themselves.



Ensure that the hydraulic piping is not used as earth sockets of the electric system or telephone lines. They are absolutely not suitable for this use as serious damage to the water pipes may be caused.



To ensure a good tightness of the water connects:

- Thoroughly clean contact surfaces.
- Lubricate threaded clamping elements (do not contaminate the seal and / or flange)

Before installing the seal ensure that the flanges are well positioned and that the faces in contact are parallel. Ensure that the gasket is centered correctly.

Do not use adhesive tapes/double sided tapes/glues to install the seal; these compromise the efficiency of the same seal.

To attain the right torque (5-10 Nm), with a correct compression of the seal, it is very important to tighten the nuts in a cross-diagram using appropriate torque wrenches.

The torque must be carried out in 5 steps:

- 1. Tighten the nuts by hand
- 2. Tighten up to 30% of the recommended end torque and check that the flange adheres evenly to the seal.
- 3. Tighten up to 60%
- 4. Tighten to the recommended torque
- 5. Tighten to the end torque for adjacent nuts to verify the correct torque.

If necessary repeat these steps more than once until you attain the final torque.

Repeat these steps after 50 hours of plant operation.

3.8 - PNEUMATIC CONNECTION

(only for versions equipped with TDS, automatic drain and water flow rate modulation valve)

To allow the correct functioning of the salinity control unit (TDS) and of the automatic drain unit (Blow Down), it is necessary to feed them with filtered and dried compressed air at a 4-6 bar pressure.

In the absence of these requirements, the units may not operate correctly.

The compressor and the tank must be positioned at a safe distance from the thermal unit, away from sources of heat.

3.9 - GAS CONNECTION

Gas connection



Danger!
The gas connection must be carried out only by a qualified installer who must respect and apply that foreseen by relevant laws in force and the local prescriptions of the supply company. Incorrect installation can cause damage to persons, animals and objects for which the manufacturer cannot be held responsible.



Before installation, we recommend a thorough inner cleaning of all fuel adduction piping to remove any residue which could jeopardise proper operation of the boiler.



Check the internal and external seal of the fuel supply system.
If using gas, the connections must be perfectly sealed.



Check that the fuel supply system is equipped with safety and control devices prescribed by the Standards in force.



If you smell gas:

- a) Do not turn electric switches on or off, use a telephone or any other object which can create sparks;
- b) Shut the gas cocks;
- c) Immediately open doors and windows to create an air current that purifies the room;
- d) Request the intervention of professionally qualified personnel.



Do not use the fuel's system pipes as earthing for electric or telephone systems.

3.10 - DRAINING CONDENSATION

CONDENSATION UPON COMMISSIONING

During the transient start-up (time necessary to bring the generator in temperature), due to the low temperature of the smoke, a moderate amount of condensation may be created.

In these conditions, it could be useful to have the condensation drained into the sewage.

For this purpose, the smoke chamber is equipped with an attachment which the exhaust pipes will be connected to according to the following notes

When the operating temperature has been reached, it is important to check that no more condensation has been formed.

If not, after having verified the actual fuel flow rates, the operating temperature should be increased.

The condensation drainage in the sewage must be:

- implemented as to prevent releasing gaseous combustion products into the environment or sewage (siphoning);
- dimensioned and implemented to allow the correct outflow of liquid waste preventing any leakage;
- installed in such a way as to prevent the liquid contained in it from freezing in the intended operating conditions;
- mixed for example with household waste water (washer, dishwasher drainage, etc.) for the most part with basic pH in order to form a buffer solution to be then introduced in the sewer system.

It is important to avoid the accumulation of condensate in the combustion product drainage system (for this reason the evacuation duct must have a slope towards the drain, of at least 30 mm / m), with the exception of any liquid head, in the drain trap of the system for the evacuation of combustion products (which must be filled after assembly and which minimum height with the boiler in operation, must be of at least 25 mm - see figure).

Do not discharge condensation through gutter drainpipes due to the risk of it turning into ice and the deterioration of the materials usually used in making the drainpipes (consult local hygiene regulations).

The drain fitting must be visible.

Due to the acidity level of the condensation (pH from 3 to 5) only suitable plastic materials must be used for the drain piping (special optional kits with neutraliser salts for acid condensation are available).

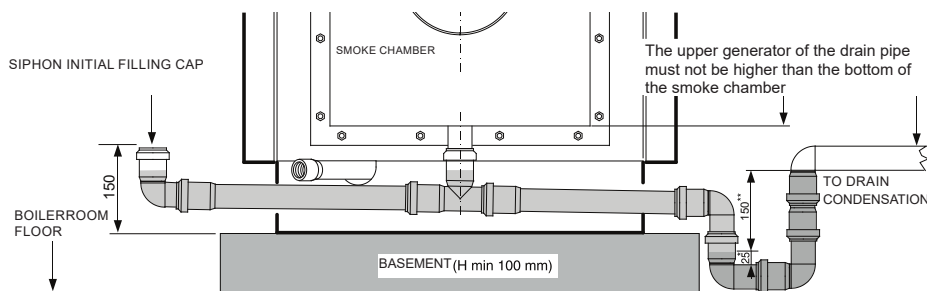

* Minimum safety siphon set by the standard

** Minimum head with boiler running at maximum power.

If you do not want to or cannot create a basement, the boiler

can be mounted at ground level and a sump at least 100 mm deep can be made to house the siphon.

3.11 - CONNECTION TO THE FLUE

The correct combination burner / boiler / chimney enables a significant reduction of consumption and an optimal fuelling with low polluting emissions.

The **FLUE (CHIMNEY)** must be resistant to heat and condensation, thermally insulated, with hermetic seal, without restrictions or occlusions, as vertical as possible and dimensioned according to the provisions of the standards in force

The **CONNECTION BETWEEN BOILER AND CHIMNEY** must be realised:

- in compliance with the regulations and laws in force,
- it must have a section that is at least equal to the smoke outlet fitting of the generator.
- with rigid conduits,
- heat resistant,
- resistant to condensation,
- to mechanical stress,
- hermetically sealed.

For the joints' seal, use materials resistant to at least 300°C.



ATTENTION:

The expulsion of exhaust gases must take place without affecting the safety of workers or third parties.



Badly dimensioned and shaped chimney and connection fittings between boiler and chimney can amplify the combustion noise, negatively influence the combustion parameters, generate condensation problems.

We would also like to remind you of the need to provide adequate cleaning devices and the withdrawal of smoke samples for combustion analysis.

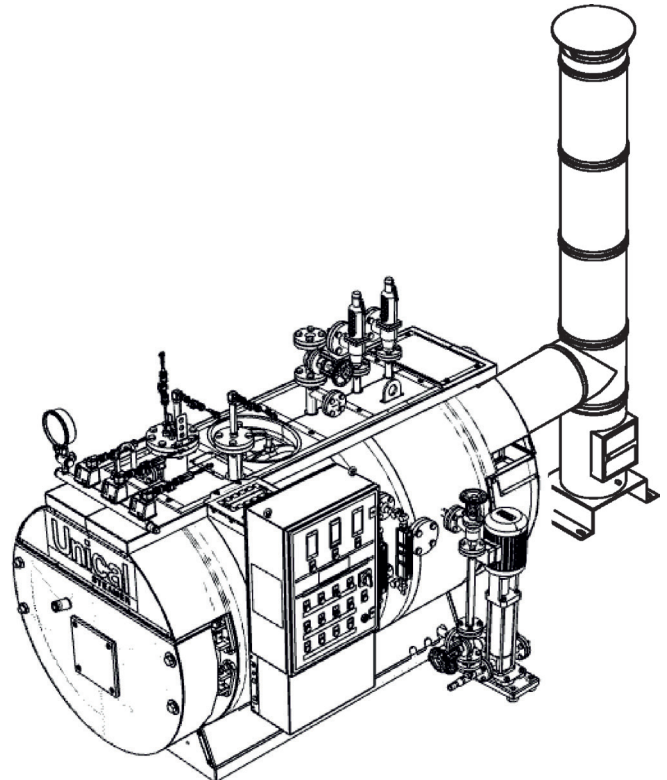

3.12 - ASSEMBLING THE BURNER



ATTENTION!
If the burner is provided by the end customer, it must strictly comply, in terms of suitability for continuous operation, with the final certification of suitability of the generator with operation without continuous supervision up to a maximum of 24 hours (or 72 hours).



ATTENTION!
The BAHR'12 OR and STD steam generators can operate with gas, diesel oil and fuel oil burners.

Note: for operation with oil burners, consult the Unical AG Technical Service beforehand



ATTENTION!
The BAHR'12 HPO/HPO EC generators can operate with gas, diesel oil and mixed gas/gas oil burners.

The BAHR'12 HP/HP EC steam generators can only operate with gas burners.

The burner must be installed according to the burner manufacturer's requirements and bearing in mind that the burner:

- a. must have thermal output suitable to thermal input (nominal input) of the steam generator;
- b. must be able to overcome the pressure losses of the generator's smoke circuit (pressurised combustion);
- c. must be fitted with a blast tube, the length of which shall meet the minimum length specified for each generator (see figure below and section 2.4 Operating data);
- d. In addition, the generator's flame sight glass must be connected to the burner's air inlet.



If the cooling tube is not connected to the flame sight glass, it could cause the glass to blacken and break.



ATTENTION: the flame sight glass can be very hot, therefore pay the utmost attention.

Burner assembly diagram

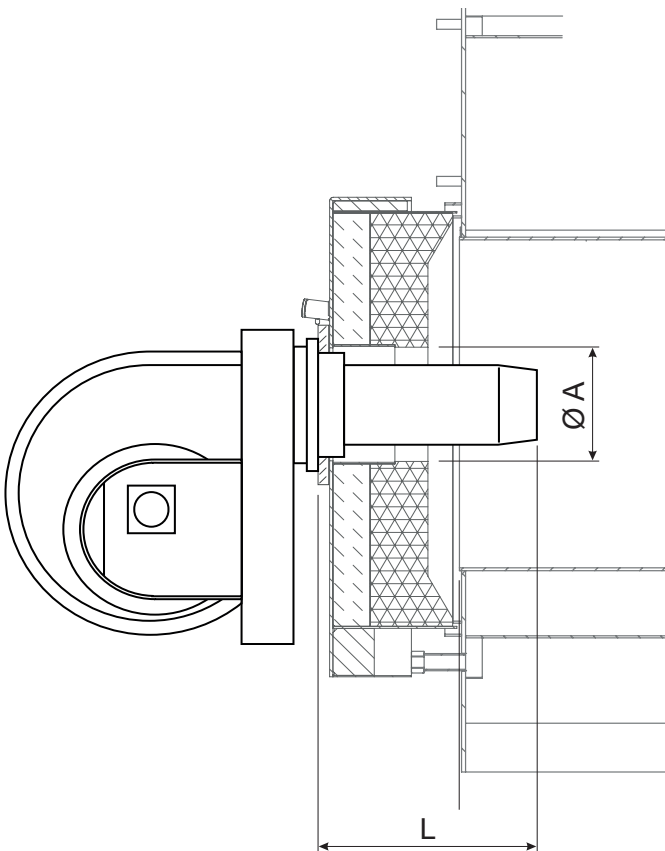

| Generator model | Burner connection (Ø A) | Blast tube length (L) | |
|-----------------|-------------------------|-----------------------|------|
| | | Min. | Max. |
| 300 - 400 | 210 | 400 | 500 |
| 500 - 600 | 210 | 400 | 500 |
| 800 - 1000 | 240 | 400 | 500 |
| 1250 - 1500 | 280 | 400 | 500 |
| 1750 - 2000 | 280 | 450 | 550 |
| 2500 - 3000 | 360 | 450 | 550 |
| 4000 - 5000 | 400 | 450 | 550 |
| 6000 | 420 | 450 | 550 |



ATTENTION!

The seat of the burner blast tube must be as precise as possible to avoid flashbacks or heat returns that would make the burner connection plate red hot.

e. If hole enlargement is imprecise or increased for easier assembly, take care, after assembling the burner, to completely and carefully fill the free space between blast tube and refractory of the front door with the ceramic fibre supplied.

f. In the presence of adapter flange for door/burner coupling, make sure the flue gas seal gaskets are mounted on both coupling surfaces.

g. Black lead the burner fixing screws to facilitate subsequent removal.



IMPORTANT
BEFORE STARTING THE BURNER,
CAREFULLY ENSURE THAT ALL SAFETY
DEVICES ARE PROPERLY CONNECTED

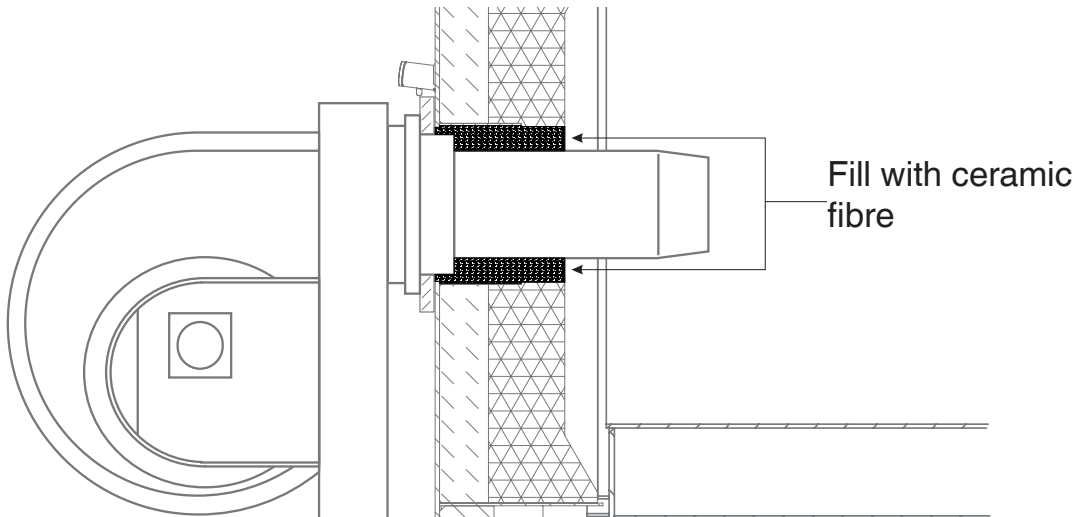

3.13 - FURNACE DOOR: ADJUSTMENT, OPENING AND CLOSING



At the first start-up, to avoid damaging the refractory insulation, operate the burner at minimum capacity or, if this is not possible, cause frequent stops to gradually warm it and obtain its "cooking".



IMPORTANT

- If it is necessary to open the door of the furnace, let it cool before opening it to avoid thermal shocks to refractory lining.
- The rear factory material of the door can show cracks after a short time of operation; this however does not reduce its insulation capacity nor jeopardise its lifespan.

The door is hinged and fixed according to the indicated diagram: In these cases, the two hinges on the left are normally used as rotation hinges (from right to left), while the two on the right are used as closing hinges.

It will be exactly the opposite when the door is opened from the left to the right.

To invert rotation, just move the lock nuts of the door.

The following adjustments can be made on the door:

- A) Adjustment in the vertical direction :** by acting on the nut of the upper hinge pin on which the door turns.
- B) Adjustment in the transverse direction :** loosen the hinges fixed on the front plate of the boiler and move them sideways.
- C) Adjustment in the axial direction :** by adjusting the tightening nuts.

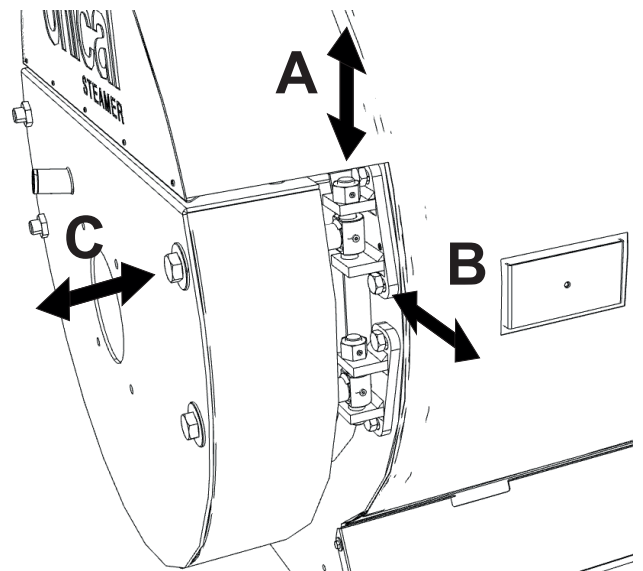

3.14- ELECTRICAL CONNECTIONS

General warnings



The electrical system must be made and checked by professionally qualified personnel in accordance with the law, who certifies the suitability:

- of the electrical system to the power loads absorbed by the generator,
- of the earthing system,
- of the cables
- of an omnipolar switch installed outside the boiler room, under current legislation.



The electrical safety of the appliance is guaranteed only when it has been properly connected to an efficient earthing system carried out as intended by safety standards in force: gas, water and heating system pipes are absolutely unsuitable as earthing electrodes.



**ATTENTION!
THE MANUFACTURER IS NOT LIABLE FOR DAMAGE TO PERSONS AND PROPERTY CAUSED BY AN UNSUITABLE EARTHING SYSTEM**

Connection to electric power supply

The generators are equipped with an electrical panel completely assembled and connected to the various accessories on the generator itself.



To connect the control panel please refer to the specific manual supplied with the panel itself (BASIC, BMI or IML).



Danger!

Only a qualified technician may perform the electrical installation.

Before performing connections or any type of operation on electrical parts, always disconnect electrical power and make sure that it cannot be reconnected accidentally.



Remember that a bipolar switch must be installed on the boiler power line with over 3 mm between contacts, easy to access, making maintenance quick and safe.

3.15 - CONTROL PANELS

IML (Industrial Multi Logic)

GENERAL FEATURES

The IML control manages all of the adjustment devices and the interface with the safety devices that are type-approved in accordance with the provisions of the regulations included in the PED.

The software functions are enabled in the relevant settings menu, depending on the installed devices, that can vary from

case to case.

The standard supply includes that it is made up from:

- metal box
- electro-mechanical power components
- Electromechanical safety components
- Electronic adjustment control, consisting of a programmable central unit and industrial Touch screen operator panel.

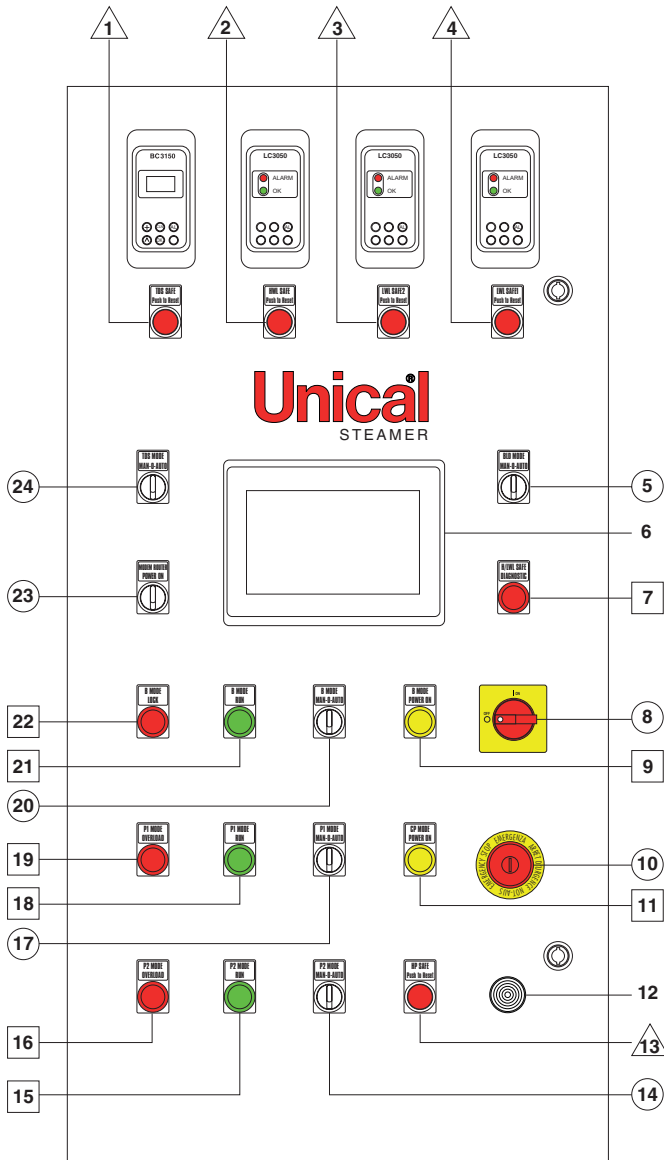

PANEL KEY

- 6 Touch Screen operator panel
- 12 Alarm siren

△ Alarm luminous buttons

- 1 TDS SAFE - Push to Reset: Salinity control unit alarm warning light (optional)
- 2 HWL SAFE - Push to Reset: High level probe alarm warning light (optional)
- 3 LWL SAFE 2 - Push to Reset: Low level probe 2 alarm warning light
- 4 LWL SAFE 1 - Push to Reset: Low level probe 1 alarm warning light
- 13 HP SAFE - Push to Reset: Safety pressure switch alarm warning light

□ Warning lights

- 7 H/LWL SAFE DIAGNOSTIC: Level probe(s) anomaly detection alarm
- 9 B MODE POWER ON: Presence of power to the burner
- 11 CP POWER ON: Presence of voltage to the electrical panel
- 15 P2 MODE RUN: Pump 2 running (optional)
- 16 P2 MODE OVERLOAD: Pump 2 circuit breaker protection intervention (optional)
- 18 P1 MODE RUN: Pump 1 running
- 19 P1 MODE OVERLOAD: Pump 1 circuit breaker protection intervention
- 21 B MODE RUN: Burner running
- 22 B MODE LOCK: Burner block

○ Selectors / switches

- 5 BLD MODE - MAN-0-AUTO: Boiler drain operating mode (optional)
- 8 MAIN SWITCH
- 10 EMERGENCY STOP BUTTON
- 14 P2 MODE - MAN-0-AUTO: Pump 2 operating mode (optional)
- 17 P1 MODE - MAN-0-AUTO: Pump 1 operating mode
- 20 B MODE - MAN-0-AUTO: Burner operating mode
- 23 MODEM ROUTER - POWER ON: Activation modem router for remote connection (optional)
- 24 TDS MODE - MAN-0-AUTO: Salinity control unit operating mode (optional)

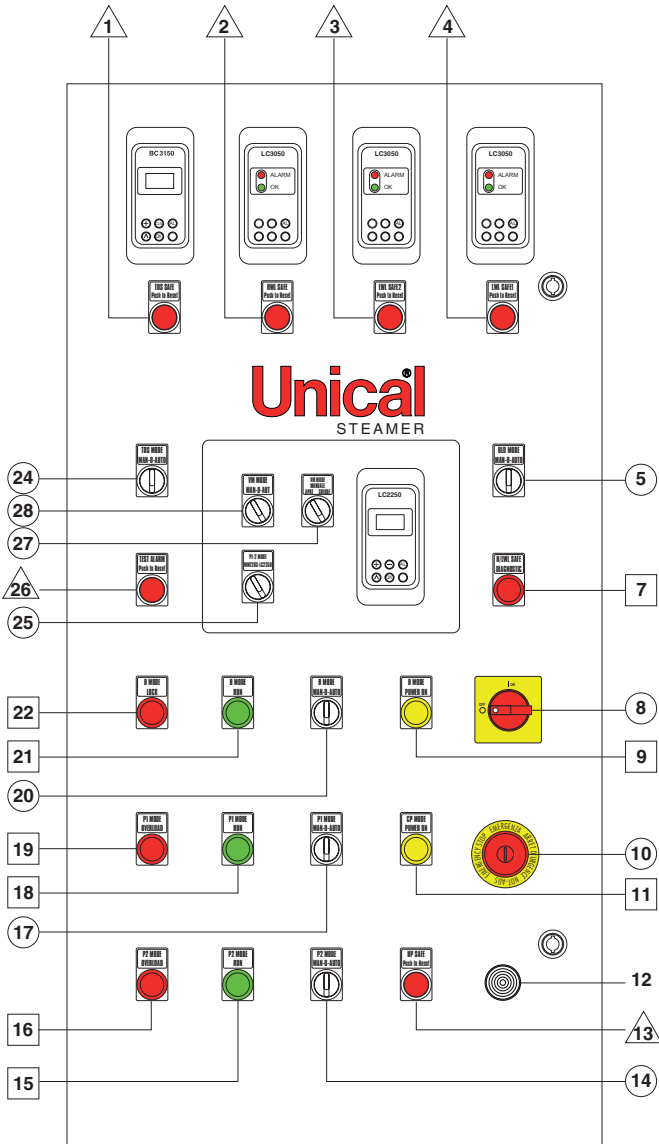

PANEL KEY

12 Alarm siren

△ Alarm luminous buttons

- 1 TDS SAFE - Push to Reset: Salinity control unit alarm warning light (optional)
- 2 HWL SAFE - Push to Reset: High level probe alarm warning light (optional)
- 3 LWL SAFE 2 - Push to Reset: Low level probe 2 alarm warning light
- 4 LWL SAFE 1 - Push to Reset: Low level probe 1 alarm warning light
- 13 HP SAFE - Push to Reset: Safety pressure switch alarm warning light
- 26 TEST ALARM - Push to Reset: Alarm warning light

□ Warning lights

- 7 H/LWL SAFE DIAGNOSTIC: Level probe(s) anomaly detection alarm
- 9 B MODE POWER ON: Presence of power to the burner
- 11 CP POWER ON: Presence of voltage to the electrical panel
- 15 P2 MODE RUN: Pump 2 running (optional)
- 16 P2 MODE OVERLOAD: Pump 2 circuit breaker protection intervention (optional)
- 18 P1 MODE RUN: Pump 1 running
- 19 P1 MODE OVERLOAD: Pump 1 circuit breaker protection intervention
- 21 B MODE RUN: Burner running
- 22 B MODE LOCK: Burner block

○ Selectors / switches

- 5 BLD MODE - MAN-0-AUTO: Boiler drain operating mode (optional)
- 8 MAIN SWITCH
- 10 EMERGENCY STOP BUTTON
- 14 P2 MODE - MAN-0-AUTO: Pump 2 operating mode (optional)
- 17 P1 MODE - MAN-0-AUTO: Pump 1 operating mode
- 20 B MODE - MAN-0-AUTO: Burner operating mode
- 24 TDS MODE - MAN-0-AUTO: Salinity control unit operating mode (optional)
- 25 P1-2 MODE - MMT203-LC2250
- 27 VM MODE - OPEN-MANUAL-CLOSE
- 28 VM MODE - MAN-0-AUT

BASIC

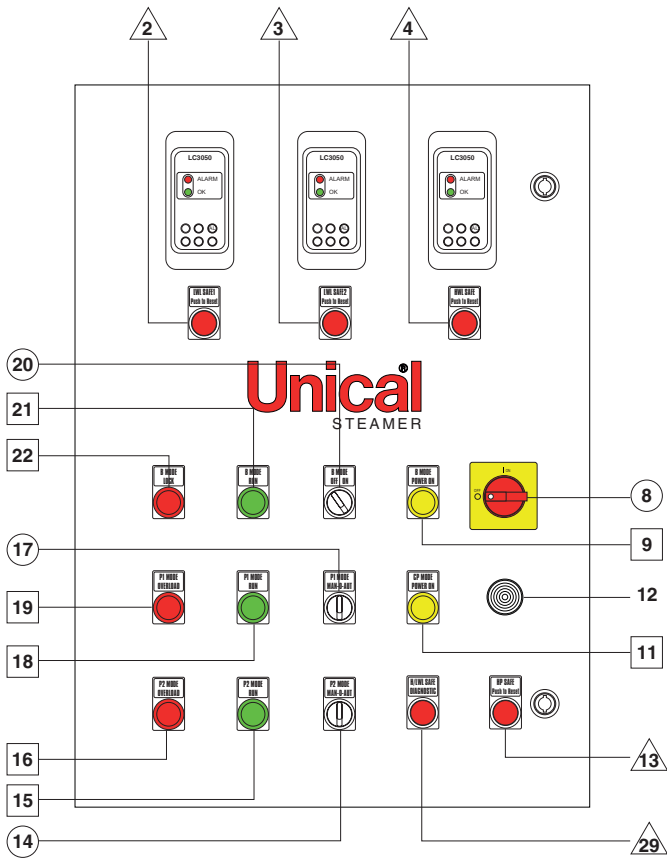

PANEL KEY

12 Alarm siren

▲ Alarm luminous buttons

- 2 LWL SAFE 1 - Push to Reset: Low level probe 1 alarm warning light
- 3 LWL SAFE 2 - Push to Reset: Low level probe 2 alarm warning light
- 4 HWL SAFE - Push to Reset: High level probe alarm warning light (optional)
- 13 HP SAFE - Push to Reset: Safety pressure switch alarm warning light
- 29 H/LWL SAFE DIAGNOSTIC: Level probe(s) anomaly detection alarm warning light

□ Warning lights

- 9 B MODE POWER ON: Presence of power to the burner
- 11 CP POWER ON: Presence of voltage to the electrical panel
- 15 P2 MODE RUN: Pump 2 running (optional)
- 16 P2 MODE OVERLOAD: Pump 2 circuit breaker protection intervention (optional)
- 18 P1 MODE RUN: Pump 1 running
- 19 P1 MODE OVERLOAD: Pump 1 circuit breaker protection intervention
- 21 B MODE RUN: Burner running
- 22 B MODE LOCK: Burner block

○ Selectors / switches

- 8 MAIN SWITCH
- 14 P2 MODE - MAN-0-AUTO: Pump 2 operating mode (optional)
- 17 P1 MODE - MAN-0-AUTO: Pump 1 operating mode
- 20 B MODE - ON-OFF: Burner operating mode

3.16- FIRST IGNITION

Preliminary checks



The installation, operation and maintenance must be carried out in compliance with the regulations in force, following the instructions described in this manual; also, any operation must be carried out by professionally qualified and authorised personnel.





ATTENTION!
ANY INTERVENTION ON THE APPLIANCE MUST BE DONE BY PERSON ENABLED TO RUN SYSTEMS, PURSUANT TO ITALIAN LEGISLATIVE DECREE 1 MARCH 1974: "RULES TO ENABLE TO RUN STEAM GENERATORS"
IT IS STRICTLY FORBIDDEN FOR PERSONS NOT SPECIFICALLY ENABLED TO USE, RUN, MAINTENANCE THE APPLIANCE.



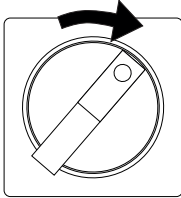
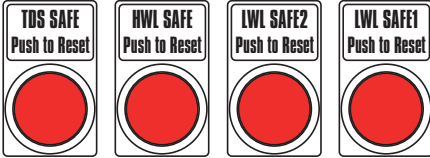
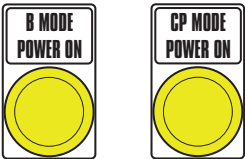
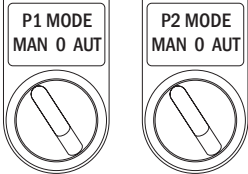
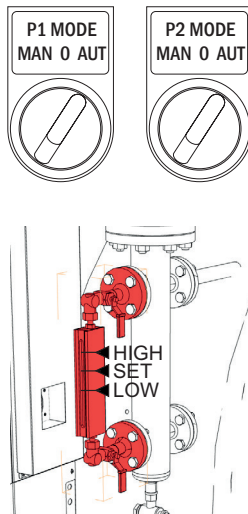

After connecting the hydraulic and electrical systems and the fuel line to the boiler, and before starting the boiler, check that:

| | |
|--|--------------------------|
| have the connections of the hydraulic, pneumatic, electric systems and fuel been connected in compliance with the national and local laws in force and as indicated in the manual? | <input type="checkbox"/> |
| the electrical parts of the generator are wired correctly? | <input type="checkbox"/> |
| the connections are fully tightened? | <input type="checkbox"/> |
| the mains voltage and frequency are compatible with the control panel of the boiler (400V 3F + N + T)? | <input type="checkbox"/> |
| is the fuel supply system dimensioned for the flow rate required for the boiler and is provided with all safety and control devices required by the standards in force? | <input type="checkbox"/> |
| the gas used (models with gas burner) corresponds to that of calibration? | <input type="checkbox"/> |
| is the gas supply cock open (models with gas burner)? | <input type="checkbox"/> |
| has gas leakage been checked (models with gas burner)? | <input type="checkbox"/> |
| Are the combustion air intake line and the flue gas evacuation line compliant with the applicable standards in force? | <input type="checkbox"/> |
| Are the ventilation conditions and minimum distances to perform any maintenance guaranteed? | <input type="checkbox"/> |
| the boiler drain and the drains are connected to the sewage? | <input type="checkbox"/> |
| is the burner assembled according to the instructions contained in the manufacturer's manual and has the burner mouthpiece infill been performed correctly? | <input type="checkbox"/> |
| have the electric connections of the safety devices on the burner been performed correctly? | <input type="checkbox"/> |
| are the refractory coverings intact? | <input type="checkbox"/> |
| are the turbolators inserted correctly into the smoke pipes (OR / STD versions)? | <input type="checkbox"/> |
| is the generator drain valve closed? | <input type="checkbox"/> |
| level indicators: the drains are closed and the shut-off valves open? | <input type="checkbox"/> |
| is the valve on the water line open? | <input type="checkbox"/> |
| is the valve on the steam inlet open? | <input type="checkbox"/> |
| is the valve on the compressed air line open? | <input type="checkbox"/> |
| are the shut-off valves in a position suitable for operation? | <input type="checkbox"/> |
| is the pump motor shaft or the pump free to rotate on a regular basis? | <input type="checkbox"/> |
| has the operator been trained and has the documentation been supplied? | <input type="checkbox"/> |

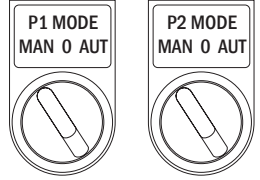
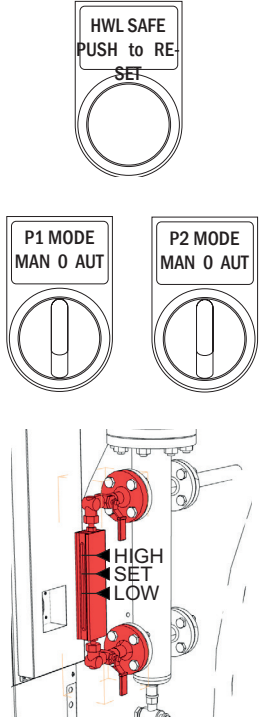
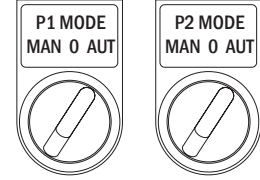
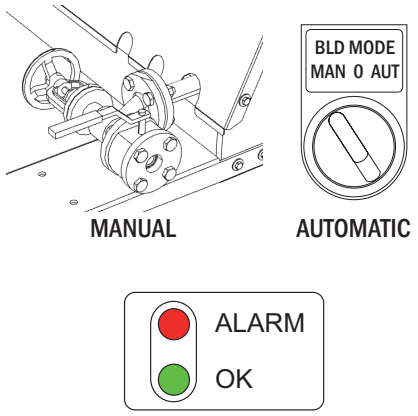
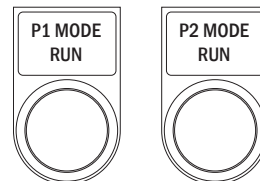
Start-up

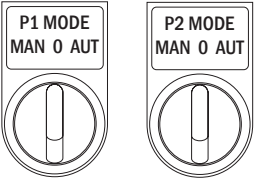
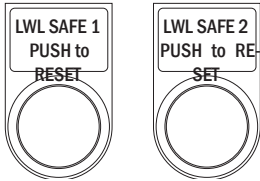
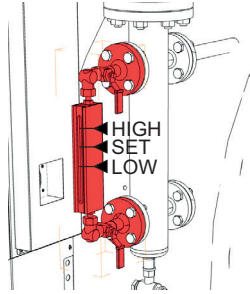
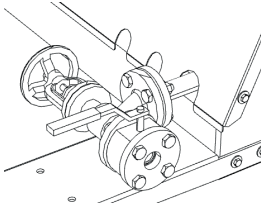
| | |
|---|--|
| <p>Verify that the selector switch ENABLE BURNER OPERATION BMODE ON / OFF is in position "OFF" (BASIC panel) or "0" (BMI / IML panel), so that the burner does not start when the panel is powered.</p> | <div style="display: flex; justify-content: space-around;"> <div style="text-align: center;"> <p>BASIC</p>  </div> <div style="text-align: center;"> <p>IMC/IML</p>  </div> </div> |
| <p>Power the control panel by acting on the main switch.</p> |  |
| <p>When the panel is switched on, the level sensors, the luminous alarm buttons:</p> <ul style="list-style-type: none"> - LWL SAFE 1, - LWL SAFE 2, - HWL SAFE (if present), - TDS SAFE (if present), <p>light-up and must be reset by pressing the buttons.</p> |  |
| <p>Check the panel voltage presence CP MODE - POWER ON and burner power BMODE POWER ON warning lights are on.</p> |  |
| <p>Start the feed pump by placing the selector switch P1 (2) MODE - MAN 0 AUT by MAN activation from the panel to check the correct shaft rotation; otherwise, reverse the phases on the CO5 removable power supply connector of the control panel.</p> |  |
| <p>Make sure water reaches the pump, bleed the air from the intake located on the upper part of the pump body.</p> <p>Start the feed pump(s) by means AUT activation from the panel and fill the generator (during the filling phase, the warning light P1 (2) MODE RUN on the panel lights-up). This operation verifies the correct functioning:</p> <ul style="list-style-type: none"> - SET probe intervention (IML panel) - pump OFF probe intervention (BASIC / BMI panel) <p>When you reach the correct level, the pumps stop automatically (the warning light P1 (2) MODE RUN is off).</p> <p>Check that the level corresponds to the one indicated on the adhesive plate applied on the side of the level indicator (if the label is not present, apply it).</p> <p>Check that there is no leakage through flanged and threaded joints</p> |  |

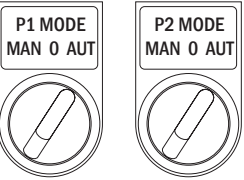
| | |
|---|---|
| <p>Start the feed pump by MANactivation from the panel, in order to force filling (the warning light P1 (2) MODE RUN lights-up).</p> |  |
| <p>Once the MAX level is reached, check the intervention of the HwL high level safety probe by the switching on of the alarm warning light HWL SAFE - PUSH to RESET on the panel.</p> <p>Stop the pump P1 (2) by turning the MODE - MAN 0 AUT selector in position 0.</p> <p>Check that the level indication HWL corresponds to that indicated on the adhesive plate (HIGH) applied on the side of the level indicator (if the label is not present, apply it).</p> |  |
| <p>Position again the switch P1 (2) MODE - MAN 0 AUT in position AUT the pump stops (the warning light P1 (2) MODE RUN is off)</p> |  |
| <p>Open the discharge line of the generator water</p> <ul style="list-style-type: none"> - version with manual discharge: act on the lever valve and hand wheel - version with automatic discharge: via MANactivation frm the panel on switch BLD MODE - MAN 0 AUT <p>During the emptying phase, check switching-off on the panel of the red LED on the level regulator HWL SAFE and the switching-on of the green LED.</p> |  |
| <p>Continue emptying the generator below the SET level to verify that the filler valve intervenes (the warning light P(2) MODE RUN lights-up).</p> |  |

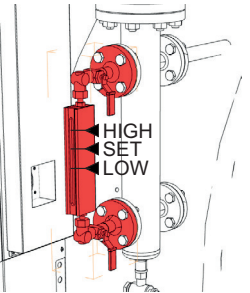
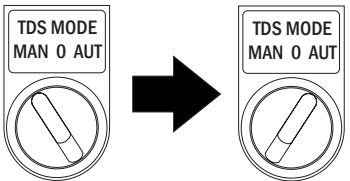
| | |
|--|--|
| <p>Turn off the pump by placing the selector in position 0 .</p> |  |
| <p>Force generator emptying below the pump SET / ON level in manual mode to verify intervention of LWL1 and LWL2 low level safety probes.</p> <p>Check that the alarm warning light LWL SAFE 1 - PUSH to RESET (LWL SAFE 2 - PUSH to RESET) switches on.</p> <p>Check that the level corresponds to that indicated on the adhesive plate (LOW) applied on the side of the level indicator (if the label is not present, apply it).</p> <p>Stop the emptying procedure:</p> <ul style="list-style-type: none"> - version with manual discharge: act on the lever valve and hand wheel - version with automatic discharge: by MAN activation from panel |     <p style="text-align: center;">MANUAL AUTOMATIC</p> |
| <p>Restore the SET level by placing the selector switch P1 (2) MODE - MAN 0 AUT in position AUT from the panel to start the pump.</p> <p>When starting the filling phase, the warning light P1 (2) MODE RUN on the panel lights-up.</p> <p>During the filling phase, check switching off of the red LEDs on the panel on the level regulators (LWL SAFE 1 and 2) and the switching on of the green LEDs.</p> <p>Upon reaching the SET level, the pump stops automatically (the warning light P1 (2) MODE RUN is off) .</p> <p>Once again, make sure that the level corresponds to the one indicated on the adhesive plate.</p> |    |
| <p>Verify the correct operation of the TDS valve (if any) by placing the TDS MODE - MAN 0 AUT selector switch in MAN position.</p> <p>Check that the valve itself opens, place the TDS MODE - MAN 0 AUT selector in AUT position.</p> |  |

Verify the correct operation of the bottom drain valve (BOTTOM BLOW DWN) (if any) by placing the **BLD MODE - MAN 0 AUT** selector in **MAN** position.

Once verified the proper operation, place the **BLD MODE - MAN 0 AUT** selector in **AUT** position.

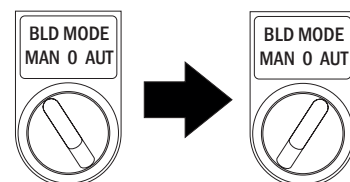

THE FOLLOWING OPERATIONS ARE DESIGNED TO PRESSURISE THE GENERATOR.



THE WORKING PRESSURE MUST BE AGREED WITH THE SYSTEM OPERATOR, BASED ON THE SAFETY PRESSURE.



ATTENTION!
POTENTIALLY DANGEROUS OPERATION.
SINCE IT IS NECESSARY TO EXCLUDE PRESSURE CONTROL AUTOMATISMS, THE FOLLOWING OPERATIONS MUST BE CARRIED OUT BY UNICAL PERSONNEL AND / OR AUTHORISED AND TRAINED FOR THE PURPOSE.

Close the steam main intake valve

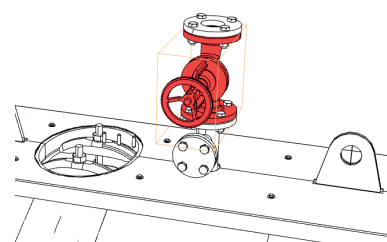

Make sure that the pressure gauge is in direct connection with the generator, checking the position of the three-way cock

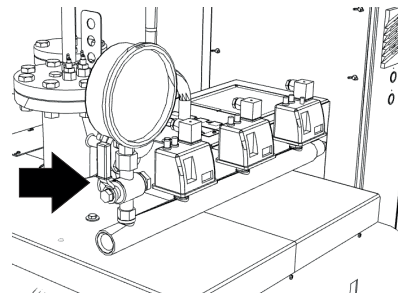



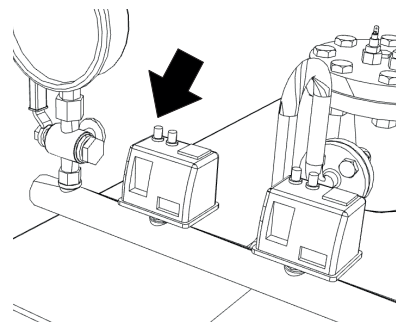

Referring to the instructions for the pressure switches (safety and work) contained in the document envelope provided with the generator, manually adjust the pressure switches at a pressure slightly higher than the calibration value of the safety valves.



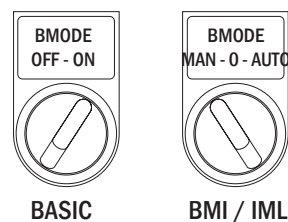

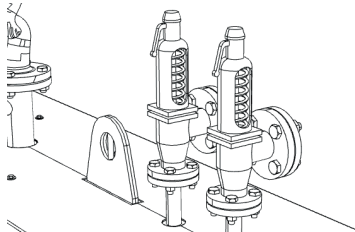
Perform the checks, calibration and start-up of the burner as per instructions of the burner Manufacturer.

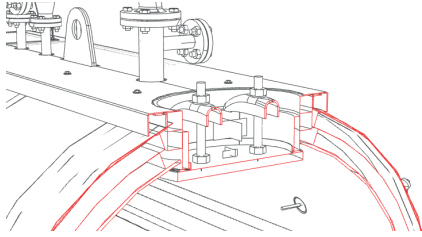
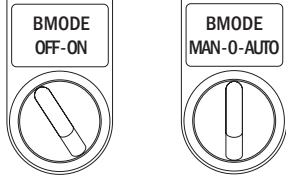
Start the burner by placing the BURnER OPERATION ENABLING **BMODE** selector in **ON** (BASIC) or **MAN** (BMI/IML) position, when the same switches on, the BURNER OPERATION WARNING LIGHT **BMODE RUN** lights-up.



| | |
|---|--|
| <p>Once the pressure value of 3-4 bar is achieved, manually act on the safety valve to check that the lever is free to move, the shutter is not stuck and it allows the venting of air.</p> |  |
| <p>Tighten the closing nuts of the MANHOLE door which may have been loosened by the pressure.</p> <p> This is an operation of fundamental importance because any leakages of steam will cause damage to the seal.</p> <p>At every increase of pressure of 2 bar tighten the locking nuts again.</p> <p>Tightening torques</p> <ul style="list-style-type: none"> - Handhole: (M16) - tighten 100 Nm - Headhole: (M20) tighten 200 Nm - Manhole: (M24) - tighten 350 Nm |  |
| <p>Increase the pressure inside the body and check on the pressure gauge that the opening pressure of the safety valves matches that of their calibration.</p> | |
| <p>Manually stop the burner by acting on the selector BURNER OPERATION ENABLING BMODE and place it in OFF (BASIC) or 0 (BMI/IML) position. When the system is switched off, the BURNER OPERATION LIGHT BMODE RUN will switch-off.</p> |  <p style="text-align: center;">BASIC IMC/IML</p> |
| <p>Gradually open the steam main intake valve to lower the pressure inside the generator.</p> | |
| <p>Calibrate (maximum pressure) the safety pressure switch.</p> <p> For the adjustments refer to the manufacturer's instructions supplied.</p> <p>The intervention pressure (pressure + differential) must be lower than the calibration value of the safety valves.</p> | |
| <p>Rearm the safety pressure switch, restart the burner and check its stop automatically by checking the pressure of intervention on the gauge.</p> <p> After verifying the correct functioning of the safety pressure switch, seal it in order to prevent any modifications by unauthorised persons.</p> | |
| <p>Gradually open the steam main intake valve to lower the pressure inside the generator.</p> | |

| | |
|---|--|
| <p>Calibrate (work pressure and differential) the working pressure switch.</p>  <p>For the adjustments refer to the manufacturer's instructions supplied.</p> <p>The pressure of intervention (pressure + differential) must be lower than the calibration value of the safety pressure switch.</p> | |
| <p>Restart the burner and check its stop automatically checking the pressure of intervention on the gauge.</p> <p>Burner restart is automatic when the pressure inside the generator has dropped by the corresponding value of the set differential.</p> | |
| <p>AT THIS POINT THE GENERATOR IS READY FOR OPERATION</p>  <p>GRADUALLY OPEN THE PRESSURE INTAKE VALVE IN ORDER TO GRADUALLY HEAT THE PIPES</p> | |

Recommendations for using the generator on the first day of operation.



- Operate the burner at minimum capacity or, if this is not possible, cause frequent stops to gradually warm the refractory and obtain its "cooking".

- Adjust the tightness of the manhole and of all water and smoke side gaskets.
- By means of the combined action of the two cocks and the drain, "clean" the conduits of communication and the crystal of the level indicator;
- Repeatedly drain the boiler bottom by rapidly opening the drain valves to eliminate possible processing residues;
- Monitor the operation of the level adjustment and pressure regulation devices.



NOTE:

The "manhole" gasket is made from reinforced carbon fibre fabric with binder.

If carrying out a "cold" hydraulic test on the new gasket, the water slowly filters through the gasket itself.

The gasket must be vulcanised. During the subsequent generator start-up, reaching 100°C vaporises the water soaking the gasket, "vulcanising" the binder and thus ensuring the subsequent sealing of the same.

3.17 - SUBSEQUENT START-UPS AND OPERATION



NOTE
If using the generator in manual mode, personnel is required to constantly monitor the level indicator.



ATTENTION!
THE SAFETY / REGULATION DEVICES MUST BE VERIFIED AT EACH START-UP.



AT LEAST ONCE A WEEK TEST THE SAFETY EQUIPMENT (PRESSURE SWITCH AND LEVEL SWITCH), BY CREATING THE REAL CONDITIONS OF INTERVENTION.

For generators equipped to operate in "Operation without the continuous supervision" of a person enabled for running, up to a maximum of 24/72 hours, the frequency of the checks is equal to the period of exemption.

| DAILY CHECKS | |
|---|---|
| COMPONENT | METHOD OF CONTROL |
| SAFETY LEVEL SWITCH (SWITCHES) | ELECTRICAL SIMULATION / INTERVENTION IN REAL CONDITIONS (BY LOWERING THE WATER LEVEL IN THE BOILER) |
| REGULATORY LEVEL INDICATORS AND ANY INTERMEDIATE POTS | PURGING THE REGULATORY LEVEL INDICATORS, OF ANY INTERMEDIATE POTS |

| | |
|----------------|---------------------------|
| Responsibility | System Manager / Operator |
| Registration | Room Manual |

| WEEKLY CHECKS | |
|-----------------------------------|---|
| COMPONENT | METHOD OF CONTROL |
| SAFETY PRESSURE SWITCH (SWITCHES) | INTERVENTION IN REAL CONDITIONS |
| SAFETY LEVEL SWITCH (SWITCHES) | INTERVENTION IN REAL CONDITIONS (BY LOWERING THE WATER LEVEL IN THE BOILER) |

| | |
|----------------|---------------------------|
| Responsibility | System Manager / Operator |
| Registration | Room Manual |

For the boiler restart process, in the case of SURVEILLANCE WITHOUT CONTINUOUS SUPERVISION (24/72), please refer to the specific manual supplied with the boiler.

- Check that all valves and all shut-off valves are in a position suitable for operation;
- check the correct position of the cocks of the pressure gauge and of the level indicator;
- check that the key selector for the operation of the electric pump is set to "AUTomatic";
- power the control panels of the burner and of the generator;
- reset the safety devices;
- once reached the working pressure value, open the steam intake valve gradually heating the pipes and removing the condensate from the delivery tube.



TO ENSURE PROPER OPERATION OF THE GENERATOR IN AUTOMATIC MODE, IT IS NECESSARY TO ENSURE PERFECT WORKING ORDER OF THE GENERATOR'S EQUIPMENT.



ATTENTION!

- Before leaving the generator under the control of automatism, visually check the operation of the pressure and level regulators (level regulator unit - adjustment pressure switches);
- THE SAFETY VALVE IS THE LAST BASTION AGAINST AN UNCONTROLLED PRESSURE INCREASE THAT CAN REACH SUCH VALUES TO CAUSE SERIOUS INJURIES;
- OPERATING PERSONNEL AND MAINTENANCE MANAGER MUST TAKE SPECIAL CARE OF THIS SAFETY DEVICE;
- It should be noted that in normal operating conditions the control and regulation devices have the purpose of preventing intervention of the safety valve that SHOULD NEVER START OPERATING;
- to avoid the shutter sticking on the seat, cause the safety valve to open by manually acting on the lever.



ATTENTION!

THE LOW LEVEL SAFETY LEVEL SWITCH IS NOT LESS IMPORTANT THAN THE SAFETY VALVE FOR THE PREVENTION OF SERIOUS INCIDENTS IN THE EVENT OF ANOMALOUS FUNCTIONING OF CONTROL PARTS. THE LACK OF WATER IN A GENERATOR WITH THE BURNER ON CAUSES A VERY QUICK COLLAPSE OF THE PRESSURISED FRAMEWORK DUE TO THE LOSS OF MECHANICAL STRENGTH BECAUSE OF THE TEMPERATURE INCREASING BEYOND THE LIMITS ALLOWED. IT IS THEREFORE NECESSARY TO PERIODICALLY CHECK (AT LEAST ONCE A WEEK) THE PROPER OPERATION OF THE SAFETY LEVEL SWITCH BY MANUALLY CAUSING THE WATER LEVEL TO DROP BELOW THE MINIMUM.

3.18 - INSTRUCTIONS FOR STOPPING THE GENERATOR

- Purge, with rapid openings, the generator and the level indicator (operation to be carried out daily even in case of continuous operation of the generator);
- close the main steam intake valve;
- remove power to the control panel;
- close the power supply circuit.



NOTE
 If the shutdown period is such to bring the generator below 100°C, it will go "Vacuum"; this does not entail any particular problems except for the auto fill of water for poor seal of the shut-off valves on the supply line (i.e. due to the effect of the starting manoeuvres).



In these conditions the system is completely "isolated" with respect to the branch out of the control unit; the generator will slowly cool without risk and will be ready to restart quickly returning to normal operation.

3.19 INSTRUCTIONS FOR THE EMERGENCY STOP OF THE GENERATOR



If, despite the observance of the starting and operation control procedures dangerous situations should arise, such as the absence of water, breakage of under pressure parts, explosion smoke side etc., it is necessary to quickly intervene by shutting off:

- the fuel
- the power supply



ATTENTION!
 IF THE FAULT IS CAUSED BY LACK OF WATER IN THE GENERATOR, CAUSING THE SHEET METAL TO BECOME RED-HOT, IT IS STRICTLY FORBIDDEN TO INTRODUCE COLD WATER; FOR SAFETY PURPOSES, CUT OFF THE SUPPLY LINE.

When the system is cold, inspect the generator to assess the damage and identify the causes that have led to the fault.

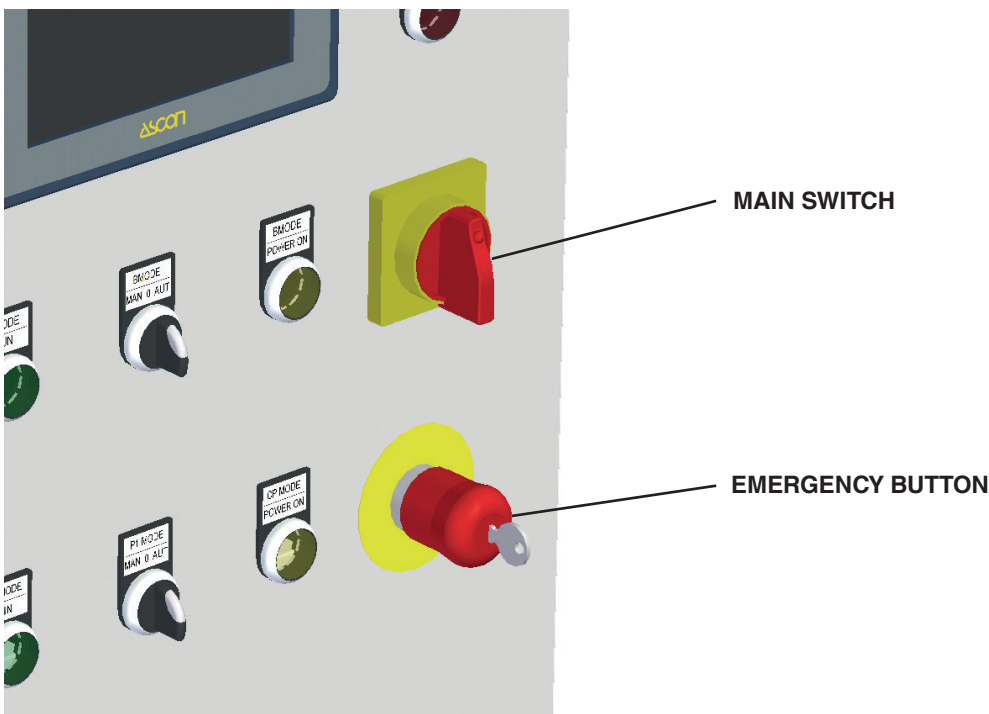

3.20 - INSTRUCTIONS FOR SHUTDOWN AND STORAGE

To avoid corrosion by inactivity in the absence of pressure, the smoke side and water side surfaces of the boiler must be treated according to the duration of the functioning interruption. There is a distinction between **wet conservation** (for which the oxygen must be kept away) and **dry conservation** (for which humidity must be kept at minimum level).

Wet conservation

Fill the generator up to the highest level with treated supply water. To prevent corrosion from oxygen, add a binder for oxygen to the boiler water (e.g. sodium sulphite) well mixed to the boiler water (thermal or mechanical recirculation).

A completely filled generator can be protected from corrosion even by keeping the pressure with nitrogen (preferably nitrogen 5.0) to a value between 0.1 and 0.2 bar.

The wet conservation with chemical products allows the oxygen to chemically bind, thus promoting protection from corrosion of the boiler materials. The wet chemical conservation is designed for steam generators during brief and prolonged inactivity periods.

Thanks to a sufficient content of binders for oxygen, to a suitable alkanisation, to proper mixing of the conservation solution and to a complete filling of the boiler and of the system, the corrosion from inactivity is easily and safely prevented.



This type of conservation MUST NOT, by contrast, be used if there is a risk of frost.



WARNING

Before starting the generator again, carry out the following operations:

- **Completely discharge the water that was used for the conservation;**
- **carefully wash and subsequently fill with clean water and properly treated.**

Dry conservation



Warning

This method must be used in the event of prolonged inactivity periods and as protection against frost. In this case, a short-term restart is not possible.

Complete emptying

After shutdown for inactivity, the boiler can be quickly emptied only when the pressure is about 3 bar. Adhere to the maximum temperature allowed for input in the public ducting network. If necessary, the water must be conveyed into a collection tank and then drained after it has cooled down.

The steam generators' water side with a high salt content in the boiler water ($> 5000 \mu\text{S} / \text{cm}$), must be washed again. Subsequently, manually open the manholes.

In dry and open boilers, apply drying products (e.g. silica gel, blue gel) in flat bowls or hang them in a way that they remain suspended and do not come into contact with the boiler materials. Close the boiler. Check the drying substances at least once a month and, if necessary, replace them.

Smoke side conservation

After putting the boiler out of service, clean the gas side of the furnace and of the smoke ducts, by opening the smoke side inspections.

It is recommended to protect the combustion chamber and the smoke passes with an anti-oxidising oil (graphite or paint). It can be sprayed or applied with a brush. The doors must be opened. Keep the surfaces dry during the inactivity period (using a drying agent, e.g. silica gel).

Close all external communications (chimney included).

4

INSPECTION AND MAINTENANCE

4.1 - GENERAL RULES FOR RUNNING STEAM GENERATORS



The yield and duration of a steam generator depend not only on a proper installation but also on good operation and maintenance.



Routine maintenance is essential in the interest of the safety, efficiency and durability of the appliance.

All maintenance must be carried out by qualified personnel.



Failure to perform Inspections and Maintenance can entail material and personal damage.



All cleaning and maintenance operations must be preceded by closing the fuel supply, after having disconnected electricity.



To ensure correct functioning and maximum efficiency of the boiler, you should properly clean the combustion chamber, smoke pipes and smoke chamber: on average every 3 months for combustion with dense naphtha, every 6 months if using diesel oil and once a year with the use of gaseous fuels.

Therefore, observe the following guidelines:

- Periodically check the proper operation and integrity of the seals of the fumes evacuation pipe; if you need to perform work or maintenance of structures located near the fume ducts and any accessories, stop the generator.
- When work has been completed and before restarting the generator, you must check with the intervention of a specialised technician the efficiency of the smoke ducts, chimney and in general all the components of the fume extraction circuit.
- At every start, after a period of inactivity, it is necessary to repeat the previously described start-up procedures.
- Periodically check the efficiency of the control and safety devices of the generator.
- Immediately remove any unburned gas leaks by replacing the worn seal gaskets.
- Periodically check (at least once a year) the parameters of combustion.



- It is forbidden because dangerous, even partially obstruct the air vents for the correct ventilation of the boiler room.

- It is absolutely forbidden to touch the hot parts of the generator which are heated and therefore burn. The same caution should also be used for at least the next hour to turn off of the burner.



NOTE

It will be the maintainer's responsibility to keep the control unit handbook updated, recording each visit with the date and the type of intervention performed.

- All the operations must be performed with the burner stopped and the generator "cold";
- in order to avoid any start-up, even accidental, it is advisable to remove the fuses of the electrical power line and signal with a sign the prohibition to actuate the switch;
- if maintenance is performed by several people, agree before starting work "who does what";
- close the fuel supply pipe;
- during cleaning wear all PPE provided for specific activities, in strict accordance with the Safety Standards;
- carefully protect all equipment;
- for cleaning, use brushes and vacuum cleaners;
- when necessary to reassemble the components removed for cleaning, carefully check the state of the gaskets and / or provide for their replacement;
- protect screws and nuts with graphite grease which will facilitate their subsequent removal;
- after having set up the generator for a long period of inactivity, provide appropriate instructions to be placed on the generator for the operations to be performed before restarting it.
- At the restart, before turning on the burner, check the operation of the generator pumps and of the system.

Instructions for routine maintenance

Carry out the following checks:

- check the mechanical and electrical efficiency of the adjustment and safety devices;
- adjust the sealing of all gaskets both on the fumes and the water sides;
- readily replace defective gaskets steam side to prevent the continuing loss of leaks damages the sealing surface of the flanges of the manhole ring;
- promptly replace defective gaskets smoke side if affecting the front door to prevent the high temperature gas leaks from causing local overheating with possible deformation of the structure;
- check the status of the feed pump;
- check the combustion parameters;
- check the efficiency of the water treatment system;
- analyse the feed and operating water to check that the values are within the prescribed range of values; in case of high alkalinity, increase boiler water drains.

Instructions for extraordinary maintenance

Soot deposits on the heat exchange walls impede the transmission of heat with decay of the yield and consequent waste of fuel.

Scale deposits on the water side of the same walls as well as produce effects similar to those described above, are the cause of breaks (cracks on the tube plates, cracks on the pipes etc.) or dangerous overheating.

Interventions to prevent the above phenomena consist in:

SMOKE SIDE:

- brushing the furnace;
- extraction of turbulators from the tube bundle;
- disassembly and cleaning of rear smoke chamber;
- cleaning of tubes by brush;
- removal of all deposits

In the meantime, check the door gaskets and thoroughly clean the rear smoke chamber and the smoke fitting;



The frequency of these extraordinary maintenance depends on the type of fuel and the combustion quality: on average every 3-4 months for combustion with dense naphtha and at least once a year with use of diesel and gas.

WATER SIDE:

- disassembly of level probes;
- opening of manhole;
- internal inspection to ascertain the presence of deposits or signs of corrosion;
- complete analysis of the feed and operating water as prescribed by the supplier of the water treatment system.

WARNINGS



The significant presence of deposits must be removed by chemical wash of the generator carried out by specialised companies;



In the presence of deposits or the beginning of corrosion (confirmed by the chemical analysis), it is necessary to service the water treatment system;



Deposits on the rods of the level control unit probes are removed by simply sanding with abrasive cloth: for the safety level switch unit probe follow the instructions of the Manufacturer of the same, attached to the document envelope with the generator;



Carefully reassemble all the components paying attention to the connections that should not be reversed.



Should it be necessary due to leaks or seeping of the safety valve, care must be taken in the possible shutter and housing grinding, operations to be requested directly from the Manufacturer of the valve.



Please note that the opening of the manhole mandatorily requires the replacement the relative gasket.

4.2 - GENERAL RULES FOR THE DISPOSAL



ATTENTION!

DISPOSAL OF THE EQUIPMENT MUST BE NOTIFIED TO THE NATIONAL AUTHORITIES (INAIL, ARPA, ASL) AND MUST BE CARRIED OUT IN COMPLIANCE WITH THE COMPULSORY LEGISLATION ON INDUSTRIAL WASTE DISPOSAL.

Malfunctions

| EVENT | PROBABLE CAUSE | POSSIBLE SOLUTION |
|--|---|--|
| Safety valve intervention | Exceeding of maximum calibration pressure of the valve | Check the intervention threshold of the pressure switches |
| | Loss of calibration of the safety valve | Check the calibration value of the valve |
| Leakage of the safety valve | Deposits of dirt around the shutter seat | Cleaning of the seat by quick and repeated drives of the manual opening lever of the valve |
| | Scratching of the shutter seat | Disassembly of the valve and polishing of the seat by means of a very fine abrasive |
| Safety pressure switch intervention | Intervention value of the PRESSURE TRANSDUCER too high | Check calibration of the safety pressure switch |
| | Faulty PRESSURE TRANSDUCER | Replacing the pressure switch |
| Safety level switch intervention | Water level detection interrupted | Rod encrusted / cable interrupted |
| Feed pump block | Pump "circuit breaker" disconnected | Check motor absorption |
| | Pump shaft blocked | Carry out maintenance |
| Insufficient water filling | Pump block | See section "Feed pump block" |
| | Valves closed | Check opening of valves / clogging |
| | Line obstruction | Check and clean the suction / delivery pipe |
| | Intake filter clogged | Clean / replace filter |
| | Anomaly level gauges | Check fault by alternating replacement (inversion) of the relay inside the panel and replace the faulty device |
| | Level adjustment probes short circuit | Disassembly of level probes and check the integrity of the ceramic insulation. Replace if necessary. |
| | Pump cavitation | Insufficient swing on the intake. Increase swing in relation to the intake water temperature |
| | | Pump filter cleaning / replacement |
| Decrease resistance of condensate collection tank duct - pump intake mouthpiece (... increase passage section/...) | | |
| Incorrect rotation direction of the pump | Invert a phase | |
| Burner always on | Incorrect electrical connection to panel | Check with wiring diagram |
| | Safety level regulator faulty | See section "Safety status level intervention" |
| | Adjustment pressure switches / pressure transducer not active | Check calibration of pressure switches / pressure transducer |
| | | Check connections of pressure switches to control panel |
| Burner not ignited | Incorrect connection to control panel | See wiring diagram |
| | Burner fuses blown / problems concerning the burner | Replace fuses / See the burner manual |
| | No consent to the burner by the PRESSURE TRANSDUCER | Replacement of PRESSURE TRANSDUCER |
| | No consent to the burner by the safety level switch | See section "Safety status level intervention" |

| EVENT | PROBABLE CAUSE | POSSIBLE SOLUTION |
|-------------------------------|---|--|
| Faulty burner adjustment | Dirt | Clean according to instructions provided in the burner manual |
| | Insufficient tightness of the smoke circuit | Check the state of the gaskets, closure of the doors, burner plate set up and connection to the chimney fitting |
| | Irregularity of the flow of fuel | Check the burner and power supply line according to the instructions given in the specific burner manual. |
| | Limescale deposits | Check presence of limescale and carry out a chemical wash |
| Lack of boiler pressurisation | Deposits of dirt in the boiler | Check cleanliness of the water side and smoke side boiler |
| | Incorrect boiler-burner coupling | Check the correct coupling of boiler-burner |
| | Incorrect burner adjustment | Check burner adjustment |
| | Insufficient burner performance | Check burner performance |
| Overheating | Incorrect choice of boiler | Check suitability of the boiler to the system |
| | Faulty safety level switch | Immediate switch-off of burner, do not introduce water in the generator do not open the door until the generator has cooled-down |

Residual risks from Risks Analysis pursuant to the European Directive 97/23/EC - PED

| | |
|---|--------------------------|
| EVENT CAUSE 21 GASKETS | Severity Event: D |
| No tightness of the gaskets on water and steam sides | |
| EFFECT - CONSEQUENCE | |
| - Leakage of water or steam from the flanged junctions and from manholes present | |
| RISK - DANGER | |
| Risk of burns due to the steam Risk of flooding of the boiler room Risk of electrical short circuit of powered parts | |
| SOLUTION - PREVENTION | |
| - It is necessary to check at start-up and periodically the tightness of all the gaskets - It is necessary to use a material that is suitable in terms of temperature, pressure, fluid - Carefully keep to that indicated in the use and maintenance manual | |

| | | |
|--|-------------------------------|--------------------------|
| EVENT CAUSE 22 | ATMOSPHERIC CONDITIONS | Severity Event: C |
| Keeping the generator in unsuitable weather conditions during transport and / or in the boiler room. These conditions refer to the minimum temperature and to the effects produced by rainwater | | |
| EFFECT - CONSEQUENCE | | |
| If the temperature is lower than that indicated in the project, they can cause fragile breakages in welds. Rainwater may damage or corrode the generator structure from the outside | | |
| RISK - DANGER | | |
| Burst of the generator | | |
| SOLUTION - PREVENTION | | |
| - Protect the generator from adverse weather conditions - Keep to that indicated in the use and maintenance manual - Check that the temperature to which the boiler may be subjected, in the expected life cycle, is in compliance with the minimum allowable of the project | | |

| | | |
|--|---------------------|--------------------------|
| EVENT CAUSE 23 | INSTALLATION | Severity Event: C |
| Incorrect installation: Hydraulic structures Electrical works Chimney | | |
| EFFECT - CONSEQUENCE | | |
| - Hydraulic: steam escaping - Electric: electrical dispersion / failed operation of the safety devices of the generator - Chimney: combustion products dispersed in the boiler room | | |
| RISK - DANGER | | |
| - Hydraulic: general burns - Electric: electrocution / explosion of the generator - Poisoning due to toxic combustion fumes (carbon monoxide) in boiler room | | |
| SOLUTION - PREVENTION | | |
| - Check the correct connection of the hydraulic connections - Check the correct connection of the electrical parts - Correctly fix the chimney - Check the correct functioning of the generator - Keep to that indicated in the use and maintenance manual | | |

| EVENT CAUSE 24 | NO MAINTENANCE | Severity Event: B |
|--|-----------------------|--------------------------|
| Maintenance not performed according to that prescribed in the use and maintenance manual | | |
| EFFECT - CONSEQUENCE | | |
| Damage produced to the generator | | |
| RISK - DANGER | | |
| Burst of the generator | | |
| SOLUTION - PREVENTION | | |
| <ul style="list-style-type: none"> - Carry out periodic preventive maintenance as defined in the use and maintenance manual - For any repairs or replacement of components comply with that indicated in the use and maintenance manual and, however, in cases not covered in this manual, consult the manufacturer of the generator | | |

| EVENT CAUSE 25 | SYSTEM SHUTDOWN | Severity Event: B |
|---|------------------------|--------------------------|
| The generator was not serviced in optimal conditions during the stop | | |
| EFFECT - CONSEQUENCE | | |
| Damage produced to the generator for effect of corrosion from oxygen in the water Damage produced by adverse weather conditions | | |
| RISK - DANGER | | |
| Burst of the generator | | |
| SOLUTION - PREVENTION | | |
| <p>The appliance must be preserved according to that described in the use and maintenance manual</p> <p>The generator must be:</p> <ul style="list-style-type: none"> - maintained at a temperature \geq to the minimum design temperature - protected from rain - stored in its internal parts, water side, as defined in the use and maintenance manual | | |

| EVENT CAUSE 26 | REPLACING ACCESSORIES | Severity Event: C |
|---|------------------------------|--------------------------|
| The replaced accessories are not suitable for the operation to be performed | | |
| EFFECT - CONSEQUENCE | | |
| Damage produced to the generator due to the lack of control of the safety functions | | |
| RISK - DANGER | | |
| Burst of the generator | | |
| SOLUTION - PREVENTION | | |
| <p>The replaced accessories:</p> <ul style="list-style-type: none"> - Must have the same characteristics of the original. - Must be equipped with the relative document in compliance with Directive 97/23/EC For the calibration, refer to the use and maintenance manual - However, it is advisable to contact the manufacturer. | | |

| EVENT CAUSE 27 | REPAIR OF THE BODY UNDER PRESSURE | Severity Event: C |
|---|--|--------------------------|
| The body was not repaired correctly | | |
| EFFECT - CONSEQUENCE | | |
| Damage produced to the pressurised body | | |
| RISK - DANGER | | |
| Burst of the generator | | |
| SOLUTION - PREVENTION | | |
| <p>For repairs, it is necessary to contact the manufacturer and the Body in charge of control in operation of the steam generators</p> <p>Legislation of reference: Italian Ministerial Decree of 1 December 2004 No. 329</p> | | |

| EVENT CAUSE 28 | TAMPERING | Severity Event: C |
|--|-----------|-------------------|
| The appliance accessories have been tampered with | | |
| EFFECT - CONSEQUENCE Damage produced to the pressurised body | | |
| RISK - DANGER Burst of the generator | | |
| SOLUTION - PREVENTION - The adjustment and safety accessories must not be tampered with - In the event of accidents due to tampering, the manufacturer is not liable. | | |

| EVENT CAUSE 29 | DECOMMISSIONING | Severity Event: C |
|--|-----------------|-------------------|
| Decommissioning was not carried out correctly | | |
| EFFECT - CONSEQUENCE Compromised structural integrity Change of use not authorised by the Body in charge | | |
| RISK - DANGER Burst of the generator | | |
| SOLUTION - PREVENTION - Carefully keep to that indicated in the use and maintenance manual - In case of accident due to incorrect decommissioning or change of use, the manufacturer is not liable. | | |

| EVENT CAUSE 30 | HANDLING | Severity Event: B |
|---|----------|-------------------|
| Violent impact during lifting and transport due to the detachment of the eyebolts or release or breakage of lifting equipment | | |
| EFFECT - CONSEQUENCE Violent impact with the ground Break of the pressurised body | | |
| RISK - DANGER Immediate danger of crushing people or objects below Danger due to any breakage in the pressurised body | | |
| SOLUTION - PREVENTION - Always keep at a distance of at least 5 m from the projection on the ground of the pressurised body during handling - In case of violent impact / falling, visually check the integrity of the pressurised body in all its parts and perform the hydraulic test again - Make sure that the lifting capacity of the handling equipment is compatible with the weight of the generator - Handle as indicated in the use and maintenance manual | | |

| EVENT CAUSE 31 | MANUFACTURING DEFECTS | Severity Event: C |
|---|-----------------------|-------------------|
| Fault present in the pressurised body | | |
| EFFECT - CONSEQUENCE Malfunctioning in normal operating conditions | | |
| RISK - DANGER Leaks from the flanged and welded junctions Burst of the generator | | |
| SOLUTION - PREVENTION - Contact the manufacturer | | |

| EVENT CAUSE 33 | FIRE | Severity Event: C |
|---|------|-------------------|
| Fire in the boiler room | | |
| EFFECT - CONSEQUENCE | | |
| Damage to the pressurised body | | |
| RISK - DANGER | | |
| Burst of generator due to body damage | | |
| SOLUTION - PREVENTION | | |
| <ul style="list-style-type: none"> - Execution of the control unit in compliance with the fire prevention regulations in force in the country of installation - Verification of the integrity of the body - Carefully keep to that indicated in the use and maintenance manual | | |

| EVENT CAUSE 34 | POOR OPERATION | Severity Event: D |
|--|----------------|-------------------|
| Operation of the generator by personnel not suitably trained | | |
| EFFECT - CONSEQUENCE | | |
| Compromise the stability and functionality of the generator | | |
| RISK - DANGER | | |
| Damage to the appliance structure with danger of explosion | | |
| SOLUTION - PREVENTION | | |
| <ul style="list-style-type: none"> - Subject the pressurised body to periodic checks - Internal Visit - Integrity check by the Body responsible pursuant to Italian Ministerial Decree of 1 December 2004 No. 329 - Carefully keep to that indicated in the use and maintenance manual | | |

Unical[®]
STEAMER



www.unical.eu

CE 00335648 - 5th Edition 06/18

Unical AG S.p.A. 46033 casteldario - mantova - Italy - tel. +39 0376 57001 - telefax +39 0376 660556
info@unical-ag.com - export@unical-ag.com - www.unical.eu

Unical shall not be held liable for any inaccuracies due to transcription or printing errors.
Furthermore, it reserves the right to modify its products as deemed necessary or useful, without affecting their essential features.