

UniGas 1000

BTU 1000

**Hand-held flue gas analyzer**

Instruction Manual MM850482 ed. 04



## INTRODUCTORY NOTE

**NOTE: THIS MANUAL IS VALID FOR INSTRUMENTS WITH SERIAL NUMBER 71707 AND FIRMWARE REV.1.002 OR HIGHER**

*This manual includes all the information you need to install, operate and maintain the flue gas analyzer **UniGas 1000, BTU 1000** and its accessories.*

***Eurotron** has used the best care and efforts in preparing this book and believes the information in this publication are accurate. The **Eurotron** products are subjected to continuous improvement, in order to pursue technological leadership; these improvements could require changes to the information of this book.*

***Eurotron** reserves the right to change such information without notice.*

*The gas analyzer uses sophisticated analogic and digital technologies. Any maintenance operation must be carried out by qualified personnel **ONLY**. **Eurotron** supplies instructions and operative procedures for any operation on the instrument. We recommend contacting our technicians for any support requirements and questions.*

*The instrument is supplied by a rechargeable battery pack or by 100, 115, 230V  $\pm 10\%$  50/60Hz main power supply.*

*The instrument is fully tested in conformity with the directive n°89/336/CEE Electromagnetic Compatibility. **Eurotron** shall not be liable in any event, technical and publishing error or omissions, for any incidental and consequential damages, in connection with, or arising out of the use of this book.*

*The operator must not use this equipment for any other purpose than that stated.*

*This document is the property of **Eurotron** and may not be copied or otherwise reproduced, communicated in anyway to third parties, not stored in any Data Processing System without the express written consent of **Eurotron***



All right reserved  
Copyright © 2004, 06

**EUROPEAN Headquarters**  
**Eurotron Instruments SpA**  
Viale F.lli Casiraghi 409/413  
20099 Sesto S. Giovanni (MI)  
Tel. : +39-02 24 88 201  
FAX: +39-02 24 40 286  
Mail: info@eurotron.com

**USA Headquarters**  
**E-Instruments Group LLC**  
172 Middletown Blvd – Suite B201  
Langhorne, PA 19047  
Tel.: 215 750 1212  
FAX: 215 750 1399  
Mail: info@einstrumentsgroup.com



## TABLE OF CONTENTS

<b>1</b>	<b>GENERAL DESCRIPTION .....</b>	<b>4</b>
1.1	Ordering Code .....	5
1.2	Specifications .....	5
1.3	Calibration certificate .....	6
1.4	Electromagnetic compatibility .....	6
<b>2</b>	<b>PHYSICAL DESCRIPTION.....</b>	<b>7</b>
2.1	Keyboard .....	8
<b>3</b>	<b>PRINCIPLE OF OPERATION.....</b>	<b>9</b>
3.1	Measurement Principle .....	9
3.1.1	Gas Sampling Probe.....	9
3.1.2	Water Trap & Line Filter.....	10
3.1.3	Gas Sensors .....	10
3.2	Auxiliary Measurements .....	11
3.2.1	Temperature Measurements.....	11
3.2.2	Pressure and Draft.....	11
3.2.3	Smoke Index Measurement (optional) .....	12
3.2.4	Measuring Instruments (optional) .....	12
<b>4</b>	<b>RECOMMENDATIONS.....</b>	<b>13</b>
4.1	Power supply .....	13
<b>5</b>	<b>CONNECTIONS.....</b>	<b>14</b>
5.1	Electro-pneumatic connections.....	14
5.2	Gas probe positioning.....	14
<b>6</b>	<b>OPERATIONS.....</b>	<b>16</b>
6.1	Flue Gas Analysis.....	16
6.1.1	Switch the instrument ON .....	16
6.1.4	Pressure/Draft Measurement.....	19
6.1.4.1	Differential Pressure Measurement.....	21
6.1.5	Draft with External Probe (optional) .....	21
6.1.6	Temperature Measurement .....	23
6.2	Leak Test Procedures.....	24
6.2.1	Let-by Test.....	24
6.2.2	Tightness test .....	26
6.2.3	Pressure Kit EE300248.....	27
6.3	Smoke Measurement.....	27
6.4	Analysis Data Print .....	29
6.4.1	Built-In Printer (option) .....	29
6.5	Carbon Monoxide Safety Room Test.....	32
<b>7</b>	<b>CONFIGURATION .....</b>	<b>34</b>
7.5	Update Instrument to Instrument (Bootload).....	39
<b>8</b>	<b>MAINTENANCE.....</b>	<b>40</b>
8.3	Error Messages .....	41
8.5	Accessories and Spare Parts .....	42
<b>9</b>	<b>CERTIFICATES .....</b>	<b>43</b>
9.1	Warranty Terms .....	43
9.2	Letter of Conformity .....	43
<b>APPENDIX .....</b>	<b>44</b>	
A1	EMC Conformity .....	44
<b>INDEX.....</b>	<b>46</b>	



## 1 GENERAL DESCRIPTION

**UniGas 1000** is designed to satisfy the HVAC market needs; but it is the result of the advanced research and experience of **Eurotron** has been developing and manufacturing portable flue gas analyzers since 1986. The **UniGas 1000** is a multi-gas, compact, Hand-held, multifunctional instrument. The micro-processor based instrument includes a flue gas analyzer, and an ambient parameters indicator. Two internal electrochemical sensors read the Oxygen (O<sub>2</sub>) and carbonic monoxide (CO) gas concentration. The gas temperature and air temperature are used in connection with the gas analysis to calculate the efficiency, excess air, and CO<sub>2</sub> concentration. A 10-gas parameters programmable table is used for calculations approved in accordance with DIN33962.

The instrument is completed with a differential pressure (draft) sensor.

- ◆ Draft measurement is possible using the internal pressure sensor and the Eurotron Group special gas sampling probe.
- ◆ The optional internal printer is impact type and the generated document is very legible and has long time shelf life.
- ◆ The UniGas has a standard IR serial interface for external HP 82240B thermal wireless printer.



### **Features & Benefits**

- **New user-friendly interface:** very intuitive and in English language to use the instrument without instruction manual.
- **Large dimensions and lighting LCD display:** very legible, large format, with automatic and manual backlight device.
- **Easy and quick upgrading** hardware and software are made using modular design to upgrade the system yourself.
- **Differential pressure measurement:** pressure, draft,  $\Delta P$ , etc.
- **Averaging** between three or more gas analysis.
- **Built-in impact type printer (option):** more legible and long-time duration for you documents.
- **Single battery pack:** rechargeable to power both the instrument and the internal printer.



## 1.1 Ordering Code

UniGas 1000 / BTU 1000 7820 – A – B – C – D – E – F

*Each Instrument is equipped standard with differential pressure and draft sensor, Tc gas temperature input, Pt100 combustion air temperature input, IR printer port, real-time clock capabilities, rechargeable battery pack, battery charger and supplied with a Report of Calibration and an instruction manual.*

<b>Table A</b>	<b>Sensor n.1</b>
1	O <sub>2</sub> (0-25%)
<b>Table B</b>	<b>Sensor n.2</b>
0	None
2	CO (0-4000 ppm), EN50379-3
2H	CO (0-8000 ppm) H <sub>2</sub> compensated, EN50379-2
<b>Table C</b>	<b>Flue gas probe (line filter and water trap included)</b>
1	180mm flue gas probe or draft (single hose) BB610047
2	300mm flue gas probe or draft (single hose) BB610048
<b>Table D</b>	<b>Option</b>
0	None
P	Built-in impact printer
<b>Table E</b>	<b>Mains adapter / charger</b>
1	115V ±10% 50/60Hz - USA plug
2	230V ±10% 50/60Hz - Schuko plug
3	230V ±10% 50/60Hz - UK plug
4	230V ±10% 50/60Hz - European plug
5	100V ±10% 50/60Hz - USA/Japan plug
<b>Table F</b>	<b>Calibration certificate</b>
1	Eurotron report

## 1.2 Specifications

- **Type:** 1 or 2 cells Hand-held flue gas analyzer.
- **Calibration:** automatic calibration procedure at 60 seconds with smart autozero switch-On.
- **Self-diagnosis:** Sensors efficiency test with diagnostic messages display.
- **Fuel types:** Up to 10 selectable from keyboard (most common preprogrammed).
- **Pump:** rate of flow 0.8 lit / head –70mbar - All data measured using 3 meters long probe and line filter connected. Load loss = 10 mbar using a 3 meters probe extension
- **Power supply:** High capacity Ni-MH rechargeable battery pack / external battery charger.
- **Charging time :** 8h at 90% with instrument off.
- **Battery life:** 6h continuous operation (without printing and back-light).
- **Printer power supply:** from the analyser battery pack.
- **Printer Report Header:** 4 programmable lines.
- **Display:** 40x58 mm alpha-numeric LCD with backlight device.
- **Infrared port:** compatible with HP82240B wireless printer
- **Smoke measurement:** Using the optional external manual pump.Index memory store and printout capability as standard.
- **Flue gas Probe:** stainless steel with rubber handle and incorporated temperature sensor. 2 meters long rubber hose included.
- **Water trap:** external with purge plug and filter.
- **Line filter:** with replaceable cartridge.
- **Working temperature:** from –5°C to +45 °C (up to 50°C for short time)
- **Storage temperature:** from –20 to +60°C (3 months maximum at temperatures exceeding the operational limits).



- **Dimensions:** 115x90x330 mm
- **Weight:** 1.1 kg (battery and printer included)
- **Warranty:** 2 years for sensors, connectors, battery, printer and pump.

### Accuracies and Ranges

Parameter	Sensor Type	Range	Resol.	Max Response	Accuracy
O <sub>2</sub>	Electrochemical	from 0 to 25.0%	0.1%	20 sec.	±0.2% Vol.
CO	Electrochemical	from 0 to 4000 ppm	1 ppm	50 sec.	±10 ppm < 300ppm ±4% rdg. up to 4000 ppm
CO H <sub>2</sub> compensated	Electrochemical	from 0 to 8000 ppm	1 ppm	50 sec.	±10 ppm < 300ppm ±4% rdg. up to 2000 ppm ±10% rdg. elsewhere
CO <sub>2</sub>	Calculated	from 0 to 99.9 %	0.1 %		
T <sub>air</sub>	Pt100	from -10 to 100 °C	0.1 °C		± 0.5 °C
T <sub>gas</sub>	Tc K	from 0 to 600.0 °C	0.1 °C		± 1 °C
ΔT	Calculated				
Pressure / draft	Piezoresistive	from -10 to 120 hPa	0.01 hPa		±3Pa <300 Pa ±1% rdg. elsewhere
Excess air	Calculated	from 1.00 to infinite	0.01		
Efficiency	Calculated	from 0 to 120%	0.1 % (also for condensing boilers with automatic detection)		
Smoke index	External pump	from 0 to 9			

- All emission measurements can be displayed with reference to a programmable O<sub>2</sub> value.
- The relative accuracy shown are expressed as absolute or % of rdg errors at -5°C to +40°C ambient temperature.
- The maximum response time shown is referred to 90% signal changes.
- The pressure relative accuracy shown is valid only after the auto-zero procedure
- Accuracy limits are stated as % of reading. An additional ±1 digit error has to be considered.
- The stated pressure relative accuracy is valid only after the zero procedure.
- Measuring reading can be directly converted from °C to °F, ppm to mg/Nm<sup>3</sup> and from hPa to mmH<sub>2</sub>O, mbar, inH<sub>2</sub>O.

Specifications may change without notice.

### Fuel technical data

The instrument includes as standard the technical data for 4 of the most common fuels. Up to 10 fuel types can be set up by factory on demand.

## 1.3 Calibration certificate

Each **UniGas 1000** portable gas analyzer is factory calibrated and certified against **Eurotron** Standards that are periodically certified by an International recognized Laboratory, and shipped with a Report of Calibration stating the nominal and actual values and the deviation errors.

## 1.4 Electromagnetic compatibility

The instrument case, made in shock-resistant injection molded ABS + polycarbonate has designed to fulfill the directive 89/336/CEE Electromagnetic Compatibility. See Appendix A1 for EMC declaration of conformity.



## 2 PHYSICAL DESCRIPTION

The UniGas portable analyzer consists of a rugged and compact case, a mother board with all base function circuits, 1 or 2 electrochemical cells, a gas pump, a keyboard, an LCD back-lit display, a Ni-MH rechargeable battery pack and, optionally, an impact printer.

The 2 pieces of the case are jointed by 8 screws. The batteries, the pneumatic circuit and the cells are positioned in the rear of the analyzer and 2 screws locking the lid.

A pressure lid allows easy removal of the paper roll.

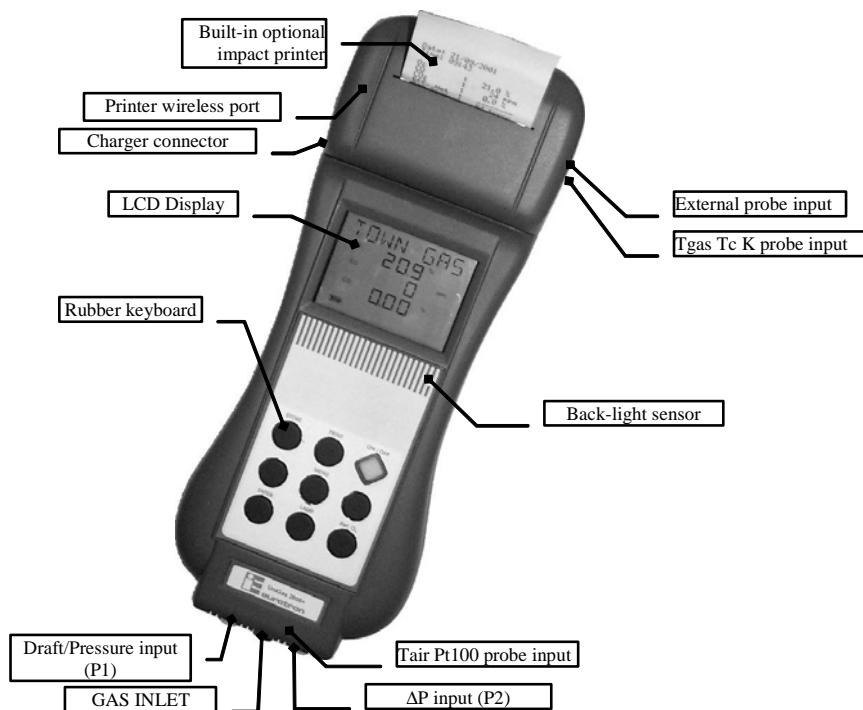

At the bottom of **UniGas 1000** you can see all sampling probe connectors: gas inlet, and differential pressure / draft inputs.

On the left side are the connectors for: line power charger and IR serial port for external wireless printer.

On the right side are the connectors for: auxiliary probes, the thermocouple type K for flue gas temperature.

The operator interface is on the front of the instrument and it consists of: a high contrast LCD display and a 9 button keypad. An automatic backlight device makes reading the data on display much easier.



## 2.1 Keyboard

The front panel keys functions are the following:



- [ON/OFF] Switches the analyzer on or off.
- [→],[↑],[↓],[←] Increase or decrease numerical values.
- [ENTER] Accepts and memory stores memory modified parameters or variables. **Pressing this key from the analysis page, the internal pump will be switched on and off.**
- [PRINT] Goes to the Printout menu page.
- [MENU] Goes to the auxiliary functions menu. Scrolls among menu options.
- [ESC] Return to the gas analysis function.
- [DRAFT] Goes directly to draft/pressure measurements page.
- [FUEL] Goes directly to fuel selection page.
- [Ref. O<sub>2</sub>] Displays the CO measurement as referred to the specified oxygen percentage.

## 2.2 Display

UniGas is designed with a large (40x56 mm) graphical display using an automatic backlight system for the best reading in poor light conditions also.

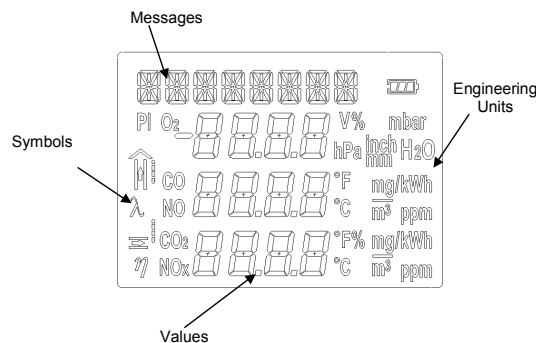

### Symbols

The display has graphical symbols to describe the actual operation mode of the UniGas 1000.

	Battery status: fully black=charged; empty=needs charging The symbol is flashing when battery is charging
	Flue gas temperature
	Ambient/combustion air temperature
$\lambda$	Excess air
$\eta$	Efficiency
PI	Poison Index. CO/CO <sub>2</sub> Ratio

### Backlight

To increase the display readability, an automatic backlight device is included.



### 3 PRINCIPLE OF OPERATION

UniGas 1000 analyzer is based on the following functional blocks:

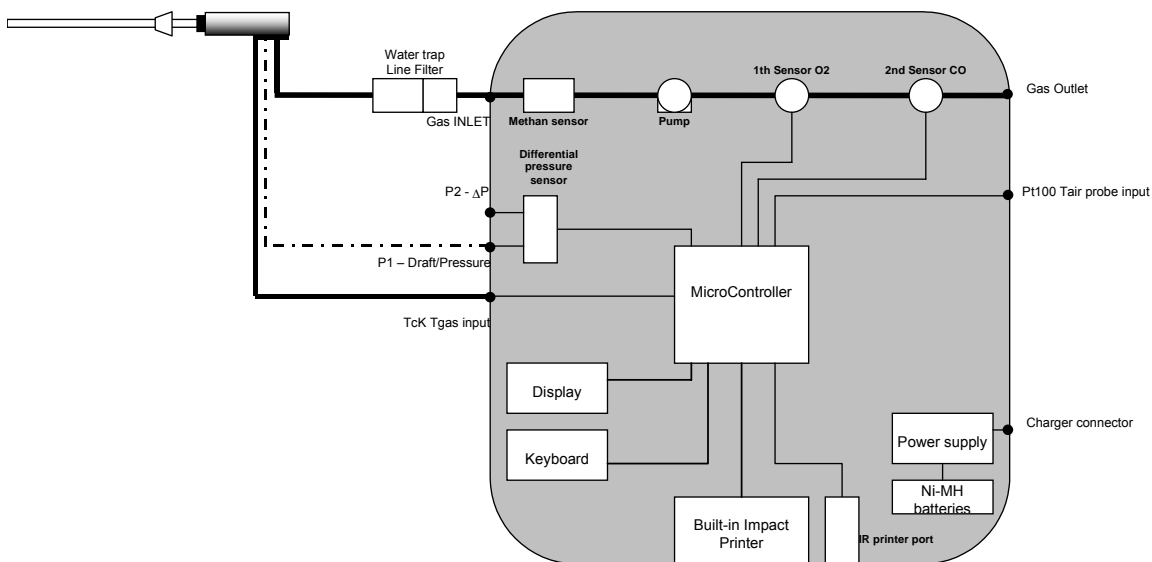

#### 3.1 Measurement Principle

The gas is sampled and aspirated through the probe with a primary pump powered at constant voltage. To position the sampling probe in the exhaust gas pathway a hole of 11mm, up to 16mm, should be drilled and the retaining cone of the sampling probe firmly screwed in it.

**The retaining screw in the cone enables the probe to be easily moved to locate the core flow, normally correspondent to the center of the section of the chimney.** The flue gas and exhaust gas pathway, should be checked for gas-tightness before carrying out a measurement and, if necessary, non gas-tight points should be sealed.

The O<sub>2</sub> sensor is essentially an electrochemical cell, with two electrodes and electrolyte solution. The behaviour is similar to a normal battery and therefore the sensitivity decreases with time.

The electrochemical cell grants accurate results for time intervals of approximately 60 minutes. The zero drift is automatically corrected by UniGas every time the instrument is switched-on, using fresh ambient air as reference. This operation should be made with the sampling probe not inserted in the chimney or with the sampling probe pneumatic connector disconnected from the analyzer gas inlet.

When a long time analysis has to be made, a new autozero procedure should be performed.

Measured and calculated parameters are indicated on a LCD alphanumeric display (40x56 mm), equipped with an automatic back light device for easy readings, also in poor light conditions.

##### 3.1.1 Gas Sampling Probe

The sampling probe consists of a steel tube and a handle of thermo insulating material. A positioning cone allows placing the probe in holes with a diameter from 11 to 16 mm.

The gas temperature is acquired using a thermocouple type K with the junction placed on the top of the tip.



### 3.1.2 Water Trap & Line Filter

The gas flows through an external combined water trap and line filter to avoid the presence of condensation and suspended solid particles in the analysis section of the instrument. A cylinder is positioned at 15 cm from the instrument gas inlet it is divided into two parts: the water trap and the line filter.

The **water trap** works using the expansion principle: the gas flow decreases its speed inside the cylinder and it will cool; the humidity will condense and the solid particles fall down. The section of the water trap must be periodically drained off to avoid water from entering the analysis section. Pull the rubber plug (cat. EE650081) and shake slowly the trap to drain the water. Push the rubber plug to close the trap hole.

The **line filter** is positioned after the water trap and before the electrochemical cell. Its function is to stop the smallest solid particles before the analysis. Remember to change the filter (cat. EE650074) every time it is dirty.

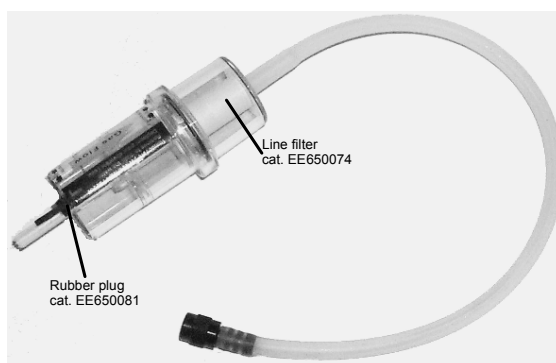

#### WARNING

**THE WATER TRAP MUST BE KEPT IN VERTICAL POSITION DURING GAS SAMPLING. AN INCORRECT POSITIONING OF THE TRAP CAN ALLOW THE WATER TO ENTER INSIDE THE ANALYZER AND DAMAGE THE ELECTROCHEMICAL SENSORS.**

**NEVER MAKE ANY ANALYSIS WITHOUT THE DRAINING RUBBER PLUG. THE MEASUREMENTS WILL BE INCORRECT.**

**WHEN YOU FINISH THE ANALYSIS, REMEMBER TO DRAIN THE WATER TRAP. BEFORE PUTTING THE GAS PROBE IN THE CARRYING CASE, REMOVE THE CONDENSATE WATER FROM THE PROBE HOSE.**

**THE LINE FILTER SHOULD BE REPLACED WHEN DIRTY. NEVER MAKE ANY ANALYSIS WITHOUT LINE FILTER AND/OR WATER TRAP, AS IT CAUSES AN IRREVERSIBLE DAMAGE TO THE ELECTROCHEMICAL SENSOR.**

### 3.1.3 Gas Sensors

The analyzer uses long life sensors for O<sub>2</sub> and CO measurements. The gas sensors are electrochemical cells composed by two electrodes (anode and cathode) and an electrolyte solution. The sampled gas goes through a selective diffusion membrane. The oxidation process produces an output electrical signal proportional to the gas concentration. The signal is evaluated by the electronics, converted to digital, processed by the microprocessor, displayed and printed with a 0.1% volume resolution.

The flue gas must not be at a pressure that could damage or destroy the sensor. Measurements are always carried out under "pressureless" conditions. The maximum permissible excess/reduced pressure is  $\pm 100$  mbar.

Each sensor has a different response time:

O <sub>2</sub>	= 20s to 90% of reading
CO (H <sub>2</sub> comp.)	= 50s to 90% of reading
CO	= 50s to 90% of reading



**NOTE: TO OBTAIN AN ACCURATE MEASURE IT IS RECOMMENDED TO WAIT 3-5 MINUTES.**

If an excessive (>150% of F.S.) gas concentration is applied to toxic gas sensor, then a  $\pm 2\%$  drift and a long resuming time can be present. In that case it is recommended to wait for a measured value lower than 20 ppm, by sucking fresh air before switching the analyzer off.

Four acoustic and visual alarm levels can be set on four programmable parameters.

## 3.2 Auxiliary Measurements

### 3.2.1 Temperature Measurements

The instrument is equipped with two temperature inputs to measure exhaust gas and the burner air input temperatures (combustion gas).

- ◆ A thermocouple type K (nickel-nickel chromium) is included in the tip of the gas sampling probe to measure the flue gas/exhaust gas temperature. This thermocouple is suitable for permanent measurements at temperatures up to 800°C and for short-term measurements up to 1000°C. Temperature measurement and gas sampling from the flue gas pathway are thus always performed at the same site. The probe is connected to the apparatus with compensated cable and connector. An internal Pt100 resistance thermometer is used for cold junction compensation.
- ◆ A remote Pt100 sensor can be supplied on request with a 2-meter cable to measure the air inlet temperature in forced air boiler. This option is very important for an accurate efficiency calculation.

### 3.2.2 Pressure and Draft

The analyzer is equipped with a temperature compensated pressure sensor to measure the chimney draft or pressure. The pressure/draft sensor is based on the principle of the extension metric measuring bridge. The pressure range is -100 to 100mbar. The sensor is factory calibrated and does not require manual adjustment. The zero drift, caused by ambient air temperature variation, is automatically cancelled at each instrument start-up. In addition, for more accurate readings the operator can reset, using the pertinent key, the zero if required. Leave open the "ΔP" connector during this phase.

**NOTE: WE SUGGEST EXECUTING THE AUTOZERO PROCEDURE FOR MORE ACCURACY BEFORE PERFORMING THE MEASUREMENT.**

#### CAUTION

**IF A SINGLE TUBE GAS SAMPLING PROBE IS USED FOR PRESSURE/DRAFT MEASUREMENTS, BE SURE THAT IT IS CLEAN AND DRIED BEFORE CONNECTING TO THE PRESSURE INPUT.**

#### CAUTION

**A +300hPa (OR -300hPa) OVER-PRESSURE CAN PERMANENTLY DAMAGE THE PRESSURE SENSOR.**



### 3.2.3 Smoke Index Measurement (optional)

This method consists of taking a gas sample from the center of the gas pipe behind the heat exchanger and crossing it through a special filter paper.

The color of the spot on the filter is compared with a graduated (from 0 to 9) reference scale and it is called "smoke index".

You can type into the instruments up to 3 smoke index values; the analyzer calculates the average value and prints these values on the report.

Normative and laws about the air pollution, describes the procedure: DIN51402, 2116, 2117 and 2297 VDI directives, ASTM D 2156-63 T, etc.

### 3.2.4 Measuring Instruments (optional)

1. **Smoke pump:** it should pull 1.63 liters  $\pm 0.07$  l (normalized to 0°C, 760mmHg) through a 1 cm<sup>2</sup> filter.
2. **Smoke index reference table:** it is a grey scale sheet with 10 different areas numbered from 0 to 9. The number 0 corresponds to an 85%  $\pm 2.5\%$  reflection. Every area reflects 10% less than the previous one. The scale is used to compare the scale with the paper filter and to calculate the smoke index.
3. **Paper filter:** When it is clean it has a reflection corresponding to the 0 scale index. It also has 3 liters per cm<sup>2</sup> a minute (normalized to 0°C, 760mmHg) with a 200/800 mmwc resistance to the air flux.





## 4 RECOMMENDATIONS

- The analyzer should be used in environments where the temperature is between -5°C and +45°C.
- When the analysis are completed, before switch the instrument off, remove the probe from the gas pathway and wait about 30 seconds cleaning the pneumatic circuit from gas.
- Do not use the analyzer with clogged filters or filled with humidity.
- Before placing the probe in the case, be sure that the probe, the water trap and the hose are clean and cold.
- If you have ordered a double hose sampling probe, insert both connectors to the instrument during the gas analysis (pay attention to colour correspondence on hose plugs).
- To empty the water trap from the condensate water, remove the draining plug. DO NOT OPEN the water trap. DO NOT leave the water trap without the draining rubber plug (cat. EE650081).
- **For the best efficiency and accuracy, we suggest calibrating the instrument every year.**

### WARNING

**IF THE UNIGAS IS STORED AT TEMPERATURE EXCEEDING THE OPERATIVE LIMITS, THE ANALYZER NEEDS SOME MINUTES TO WARM-UP TO THE ACTUAL AMBIENT TEMPERATURE, BEFORE STARTING THE OPERATION.**



### 4.1 Power supply

UniGas can be powered from:

- internal rechargeable Ni-MH battery.
- External battery charger, supplied as a standard accessory (the batteries must be installed).
- Optional external DC auto battery charger (the batteries must be installed).

The Ni-MH rechargeable batteries allows a long operation time and do not need maintenance. The same batteries power both the instrument and the internal printer. The internal battery will grant 6 hours continuous operation (without printing and display back light off).

**NOTE: 90% BATTERY CHARGING CAN BE OBTAINED IN 8 HOURS WITH THE UNIGAS SWITCHED OFF.**

During operation a fully battery symbol “” will be displayed on the display. This symbol means that the batteries are completely full. When the batteries will be discharged the symbol “” will appear and the instrument still has about 20 minutes operation capability to end the running analysis.

The battery symbol indicates that a full charge is required. Use only the dedicated battery charger supplied by Eurotron together the instrument.

**CAUTION: OLD BATTERIES CAN LEAK AND CAUSE CORROSION. NEVER LEAVE RUN DOWN BATTERIES IN THE INSTRUMENT**

### WARNING

**THE INSTRUMENT IS SHIPPED WITH AN AVERAGE LEVEL OF BATTERY CHARGE. AFTER UNPACKING, A FULL CHARGE OF THE BATTERY IS RECOMMENDED, BY CONNECTING THE INSTRUMENT TO THE MAIN LINE THROUGH THE BATTERY CHARGER (OFF CONDITION) FOR 8-10 HOURS AT A TEMPERATURE BETWEEN 10 AND 30°C**



## 5 CONNECTIONS

### 5.1 Electro-pneumatic connections

To prepare the instrument for operation, connect the sampling probe to the instrument:

- Plug the pneumatic connector of the probe to the GAS INLET connector. If you are using the gas sampling probe with Draft option (double hose model), connect also the draft connector to the UniGas Pressure/Draft inlet (P1).
- Plug the probe temperature sensor plug to the pertinent connector.
- If necessary, plug the remote air temperature Pt100 sensor to the pertinent connector.

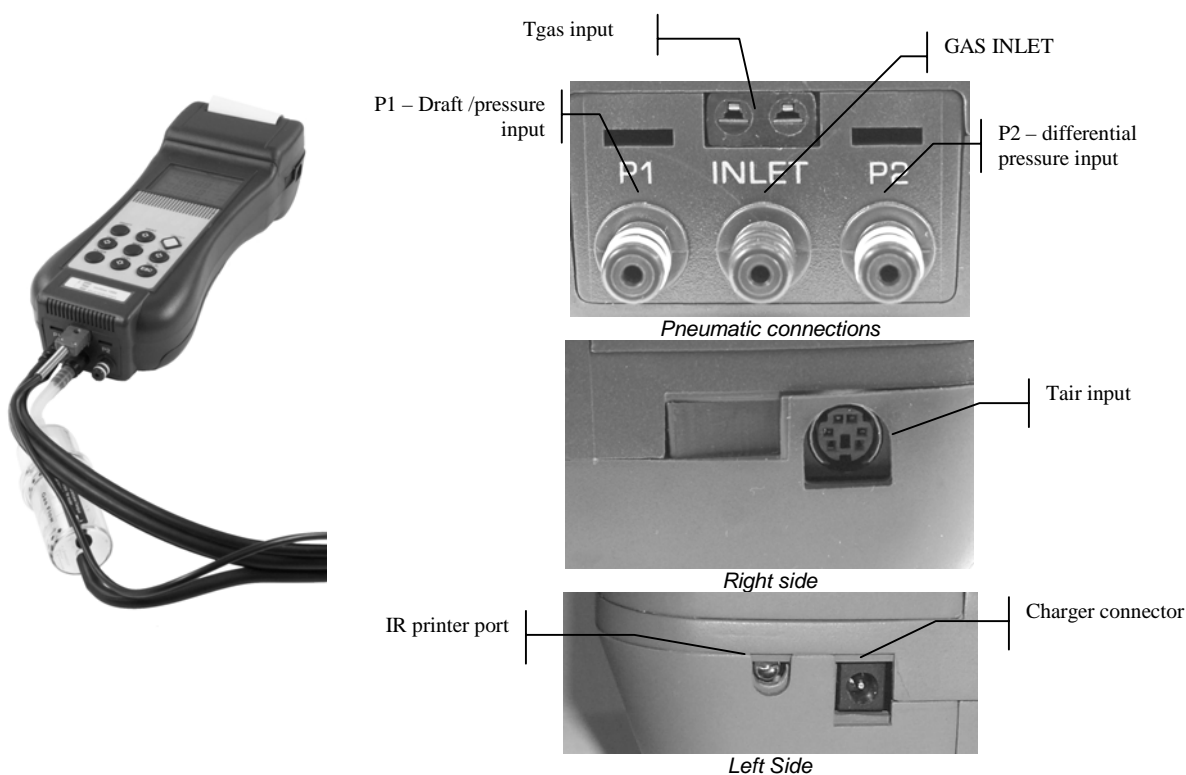

#### WARNING

**BEFORE STARTING THE GAS ANALYSIS PROCEDURE BE SURE THAT:  
PROBE DRAFT CONNECTOR (P1) AND GAS SAMPLING CONNECTOR (INLET) ARE PLUGGED TO THE INSTRUMENT;  
DRAINING PLUG IS WELL INSERTED IN THE WATER TRAP;  
LINE FILTER IS CLEAN.**

### 5.2 Gas probe positioning

The measurement site should be arranged at a distance of  $2xD$  behind the exhaust gas connection pipe, where  $D$  = diameter of the exhaust gas connection pipe.

To position the sampling probe in the exhaust gas pathway a hole of 11/16mm should be drilled and the retaining cone of the sampling probe firmly screwed in it.



The retaining screw in the cone enables the probe to be easily moved in order to locate the core flow, normally correspondent to the center of the section of the stack.

The flue gas and exhaust gas pathways must be checked for gas-tightness before carrying out a measurement and, if necessary, non gas-tight points should be sealed.

To locate the gas core flow insert progressively the sampling probe and read the maximum value of temperature.

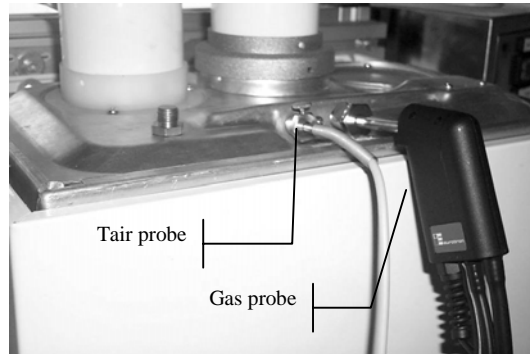

#### CAUTION

**FOR A CORRECT GAS ANALYSIS, NO AIR MUST REACH THE FLUE GAS AS A RESULT OF NON-GAS-TIGHT CONNECTION POINTS BETWEEN THE HEAT PRODUCER AND THE MEASUREMENT SITE (PROBE).**

**THE FLUE GAS AND EXHAUST GAS PATHWAYS MUST BE CHECKED FOR GAS-TIGHTNESS BEFORE CARRYING OUT A MEASUREMENT, AND IF NECESSARY NON-GAS-TIGHT POINTS SHOULD BE SEALED.**



## 6 OPERATIONS

All the procedures and programming operations on **UniGas 1000** can be made using the keyboard and the display.

**NOTE: ALL NUMERIC VALUES SHOWN IN THE FIGURES OF THIS MANUAL ARE INDICATIVE AND LISTED AS AN EXAMPLE.**

The analyzer should be used in environments where the temperature does not exceed the specified limits (from -5°C to +45°C) and where the relative humidity is lower than 95% non-condensing.

### 6.1 Flue Gas Analysis

#### 6.1.1 Switch the instrument ON

- Connect the gas probe to the analyzer as shown in chapter 6. **DO NOT INSERT THE PROBE IN THE CHIMNEY/ STACK WHEN UNIT IS GOING THROUGH ITS 60 SECOND AUTO CALIBRATION.**
- Switch the analyzer on pressing the [ON] key. The display will show the following page:



This page changes automatically after a few seconds or if you press a key as follows:

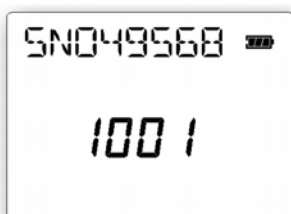

This page changes automatically after some a few seconds or if you press a key as follows:



This page displays the remaining seconds until the end of the autozero procedure.

**NOTE: THE ANALYZER MUST DRAW CLEAN AMBIENT AIR FROM THE AMBIENT DURING THE AUTOZERO PROCEDURE. OTHERWISE THE MEASUREMENTS MAY NOT BE ACCURATE AND A SENSOR ERROR MAY OCCUR.**



When autozero procedure finishes, and no error occurs, a beeping sound advises the operator. The standard autozero time is set for 60 seconds. If one or more sensors have a problem, the unit will perform another autozero procedure.

- Press the [ENTER] key to mute the unit. The following page will be displayed:

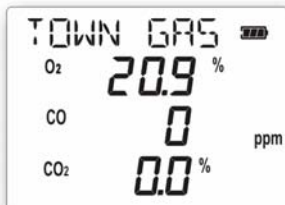

- The BTU/UNIGAS 1000 is now fully ready for flue gas analysis and any other measurements.

**NOTE:** AFTER THE INSTRUMENT IS SWITCHED ON, ALL SETTINGS WILL BE SET TO HOW IT WAS WHEN IT WAS TURNED OFF.

### 6.1.2 Flue Gas Analysis

- Insert the probe in the chimney. Stop using the retaining cone and adjust the immersion depth for a gas sampling in the middle of the exhaust gas connection pipe.
- Plug the pneumatic connector of the probe to the GAS INLET connector. If you are using the gas sampling probe with Draft option (double hose model), connect also the draft connector to the UniGas Pressure/Draft inlet (P1).
- Plug the temperature connector of the sampling probe to the pertinent TcK connector.
- If required, plug the remote air temperature Pt100 probe to the pertinent connector. It is important to measure the true combustion air temperature to have a correct boiler efficiency calculation. Unigas has an auxiliary Rtd input to measure simultaneously the air temperature. A Pt100 with a 2 meters long cable can be connected on the right side of the analyzer. Insert the Rtd inside the air combustion aspiration tube and near the boiler. The UniGas will show the temperature on the display and the efficiency will be calculated using this value. If no external Rtd is connected, the analyzer will measure the instrument temperature (ambient) using the internal sensor.

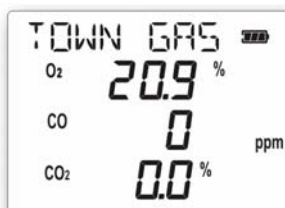
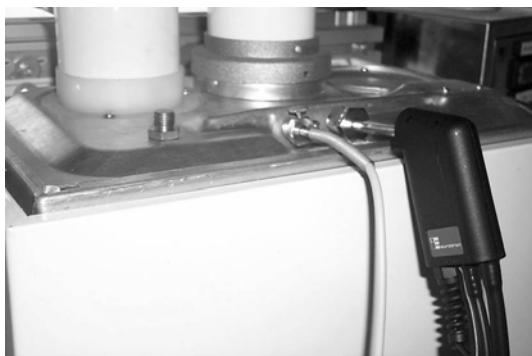

Pressing the [◀] and [▶] keys you can change page to display all other parameters

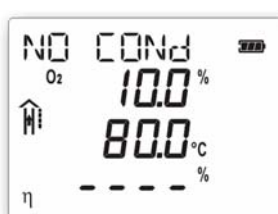
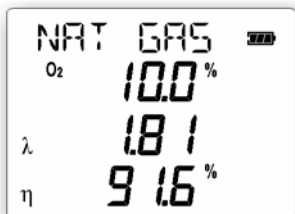

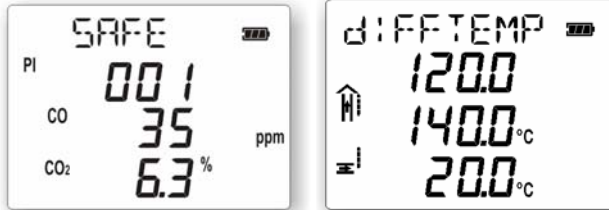

By pressing the [REF. O<sub>2</sub>] key, the measured parameters will be referred to the user defined programmed oxygen value. When selecting this mode, the first line on the top of the display will be replaced by the message "REF O<sub>2</sub>CO".

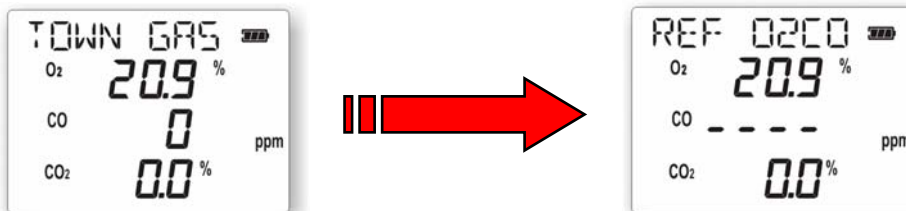

**NOTE:** THE INSTRUMENT AUTOMATICALLY DETECT A CONDENSATING OR A NOT CONDENSATING BOILER. IF A CONDENSATING BOILER IS DETECTED, THE DISPLAY WILL CHANGE AS FOLLOWS, AND THE CONDENSING EFFICIENCY VALUE WILL BE DISPLAYED:

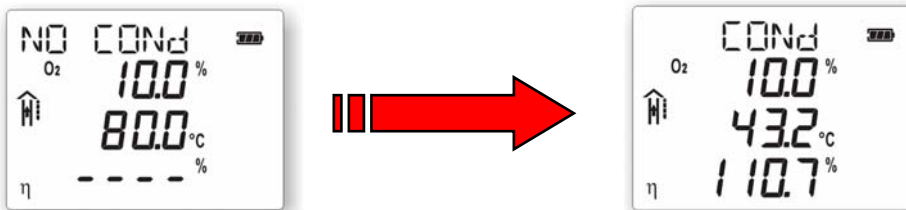

### 6.1.3 Fuel Type Set-Up

In the measuring page the set fuel type is displayed on the first row

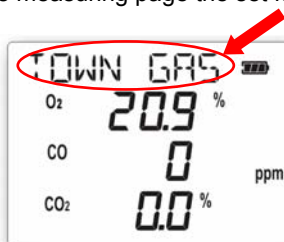

To change the fuel type use the following procedure:



- Press the [FUEL] key to display the following page:



- Use the [▲] and [▼] keys to change the fuel type

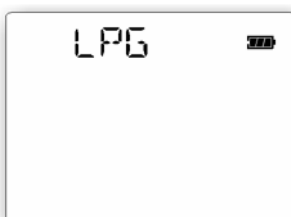

- Press the [ENTER] key to store the value.
- Press [ESC] to return to the measure page.

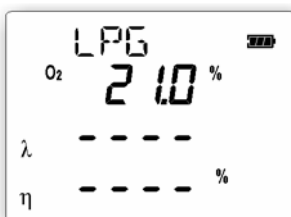

#### 6.1.4 Pressure/Draft Measurement

The UniGas 1000 has a built-in internal differential pressure sensor. With this sensor, you can execute the pressure/draft measurements by using the standard probe or the special dual-hose probe.

**Standard single hose probe:**

The standard probe has one gas collector for gas sampling. Usually you have the hose terminal connected to the gas inlet; when you have to do the draft measurements you have to move the connector to the pressure inlet (INLET) connector (PI).

**Special dual hose probe:**

This special probe model has two gas collectors: one is for the flue gas analysis and the other one is for the draft measurement. When connecting the probe to the analyzer be sure to connect both the gas inlet (INLET) and pressure inlet (P1) connectors. Connect the hose with the line filter to the gas inlet connector.

**CAUTION**

**IF YOU USE A SINGLE TUBE GAS SAMPLING PROBE FOR PRESSURE/DRAFT MEASUREMENTS, BE SURE THAT PROBE AND THE HOSE ARE CLEAN AND DRY BEFORE CONNECTING THEM TO THE PRESSURE INPUT.**



From the main page

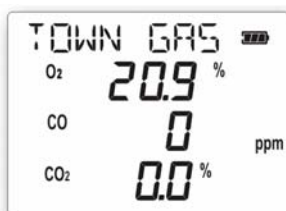

- Press the [DRAFT] key:



**NOTE: DO NOT INSERT THE PROBE INSIDE THE STACK.**

- Press the [ENTER] key before inserting the probe in the stack to zero out the measured value.



- Insert the probe in the stack. Check for mechanical positioning and flue gas intercepting. Wait for measurement stabilization.



**NOTE: TO STORE THE DRAFT VALUE AND PRINT IT ON THE FLUE GAS ANALYSIS REPORT, PRESS THE [DRAFT] KEY. THE PRESSURE PAGE WILL CHANGE AS FOLLOWS AND THE "M" SYMBOL WILL BE DISPLAYED.**



- Press [**DRAFT**] again if you want remove the HOLD function, or press the [**ENTER**] key if you to maintain the HOLD function.
- Press [**ESC**] anyway to return to the measuring page.

### 6.1.4.1 Differential Pressure Measurement

Using the burner pressure probe (cat. EE300088), it is possible to measure the gas pressure on the burner. Connect the probe to the UniGas pressure input and then to the burner plug. Follow the procedure described in the previous paragraph to perform the measurements.



Differential pressure can also be measured by the gas analyser using the P1 and P2 inputs.

### 6.1.5 Draft with External Probe (optional)

The external probe for the draft measurements (BB830025) it's a special pressure meter that features advanced specifications and resolution compared to the built-in one. Its range is  $\pm 200$  Pa and its resolution is 0.1 Pa. The pressure sensor is calibrated in factory.

- Connect the probe to the instrument using the probe connector and connecting it to the instrument plug (see the figure below)



- Put the **sensor** in **vertical position** on the body of the boiler using its magnet
- Put the tip possibly at the same height of the sensor using its magnet (see the figure below)

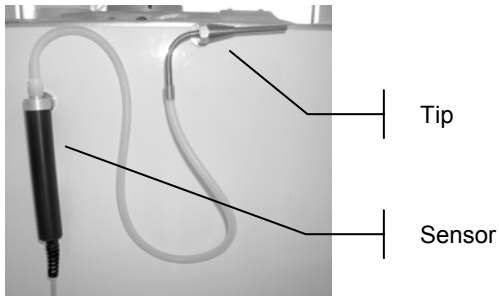

Start from the measuring main page:



- Press the [MENU] key until the following page is displayed:



**NOTE: DO NOT INSERT THE PROBE INSIDE THE STACK**

**WARNING**  
Do NOT MOVE THE SENSOR DURING THE FOLLOWING OPERATIONS

- Press the [ENTER] key to enter the zero page



- Press the [▼] key (**make sure that both the sensor and the probe are installed in vertical position and still**) to zero the sensor
- Insert the tip in the stack (chimney) and fix it using its cone support



- Press the [ENTER] key: the depression value will be displayed on the following page



**NOTE:** TO STORE THE DRAFT VALUE AND PRINT IT ON THE FLUE GAS ANALYSIS REPORT, PRESS THE [DRAFT] KEY. THE SYMBOL "M" WILL BE DISPLAYED INSTEAD OF THE "E"



- Press [DRAFT] again if you want remove the HOLD function (the draft value will not be printed on the gas analysis report)
- Press [ESC] to return to the measuring page.

## 6.1.6 Temperature Measurement

The flue gas analyser is equipped with two temperature inputs for Pt100 and TC Type K probes. The temperature probes are useful to measuring air, water and contact temperature. Connect the Pt100 probe to the "Tair" input as shown in figure 1.

Connect the TC Type K probe to the mini-DIN compensated "Tgas" input as shown in figure 2. The instrument features the compensation of the cold joint: it means that of a Pt100 thermoresistance detect the temperature in correspondence of thermocouple connector.







FIG.1



FIG. 2



TC K PROBES	
	Pipe Velcro F2139000
	130 mm Air F2132100
	130 mm Contact F2137100
	Clamp probe F2139100
Pt100 PROBES	
	Clamp probe F2139200

## 6.2 Leak Test Procedures

This operative mode allows the operator to perform the gas network leak test with pressure decay procedure. Before starting the test you have to isolate and to empty the gas network section to be tested.

### CAUTION

**BE SURE TO EMPTY AND CLEAN THE CIRCUIT: OVERPRESSURE, DUST, LIQUID BECAUSE CONDENSATION MAY DAMAGE THE INSTRUMENT'S INTERNAL CIRCUITS.**

### CAUTION

**A +300hPa (OR -300hPa) OVER-PRESSURE CAN PERMANENTLY DAMAGE THE PRESSURE SENSOR.**

### 6.2.1 Let-by Test

To perform the leak test, press the **[MENU]** key from measuring page until the following page is displayed:





**WARNING**  
**DO NOT PRESSURIZE THE GAS NETWORK**

- Zero the sensor by pressing the [▼] key.
- Pressurize the gas network using air or gas media.
- Press the [ENTER] key to start the test.

**NOTE: THE INSTRUMENTS WILL WAIT FOR 5 SECONDS (THE ZERO VALUE ON THE PAGE WILL BLINK) AND THEN THE PAGE WILL CHANGE AS FOLLOWS:**



**WARNING**  
**THE MAXIMUM OPERATIVE PRESSURE IS 120 HPA (120 MBAR). DO NOT EXCEED THIS PRESSURE VALUE**

The instrument will display the initial pressure and a 60 seconds countdown will start. When the countdown ends the following page will be displayed:



- Press the [PRINT] key to print the test report

```
Your company name
Phone number here
Fax number here

UniGas 1000
Serial Number 119001

Date: 29/09/2006
Time: 14:44

Let by Test
Compliant to IGE/UP/1B

Start P1: 1.85 mbar
Finish P2: 0.04 mbar

Drop      : -1.81 mbar
Duration  : 60 secs
```

**LEGEND**

**P1-P2:** pressure measurements  
**DROP :** Pressure Drop (P2-P1)  
**Duration :** Test Time

- Press [ESC] to return the measuring page



## 6.2.2 Tightness test

- To perform the tightness test, press the [MENU] key from measuring page until the following page will be displayed:



**WARNING**  
**DO NOT PRESSURIZE THE GAS NETWORK**

- Zero the sensor by pressing the [▼] key.
- Pressurize the gas network using air or gas media.
- Press the [ENTER] key to start procedure. The following page will be displayed:



**WARNING**  
**THE MAXIMUM OPERATIVE PRESSURE IS 120 HPA (120 MBAR). DO NOT EXCEED THIS PRESSURE VALUE**

The instrument will display the initial pressure and a 60 seconds countdown will start. This is a stabilization time.

When the countdown ends, displayed page will change as follows and a 120 seconds countdown will start



When the 120 seconds countdown ends the  $\Delta P$  value will be displayed on the following page:

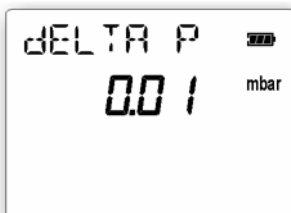



- Press the [**PRINT**] key to print the test report.

```
Your company name
Phone number here
Fax number here

UniGas 1000
Serial Number 119001

Date: 29/09/2006
Time: 14:44

Tightness Test
Compliant to IGE/UP/1B

Start P1: 3.53 mbar
Finish P4: 0.06 mbar

Drop      : -3.48 mbar
Duration  : 120 s
```

#### LEGEND

**P1-P4:** pressure measurements  
**Drop:** pressure drop after the test end (P4-P1)  
**Duration :** Test Time

- Press the [**ESC**] key to return the measuring page.

### 6.2.3 Pressure Kit EE300248

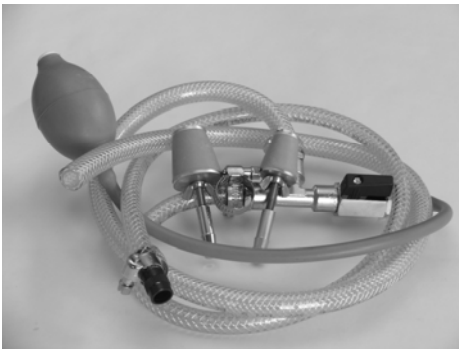

This pressure kit has been designed to perform the leak tests.

Individual elements (contents of case):

- n° 2 conical gas test plugs with nipple to connect the adapters to the gas network
- n° 1 hand bellow for pressurize the gas networks
- n°1 'T' adapter with gas cut-off valve
- n°1 connector for the analyser input

### 6.3 Smoke Measurement

To avoid condensation inside the smoke pump, the pump should aspirate ambient air before the gas sample. This can be obtained aspirating the air by the fireside (not in the exhaust gas connection pipe) without using the paper filter.

Now introduce the filter in the pump.



The gas sample should be drawn to the centre of the combustion gas flux. The correct gas volume is sampled with 10 uniform shoots by the pump. We suggest using a retaining cone during gas sampling. Compare the darkening of the filter with the smoke index comparing table. The smoke index found should not exceed the ones defined by the current normative.



### 6.3.1 Input of the Smoke Index

Before input the data, you have to execute the smoke index measurements. You can input up to 3 separate values; the analyzer will make the average calculations. These values will be printed on the final report with the other gas analysis data.

- Press the [MENU] key until the following page will be displayed:





- Press [ENTER] and input the smoke index values into the following page:



- Change the 1st test value by pressing the [▲] and [▼] keys. Press the [ENTER] key to store the value and input the test 2 value.
- Change the 2nd test value by pressing the [▲] and [▼] keys. Press the [ENTER] key to store the value and input the test 3 value.
- Change the 3rd test value by pressing the [▲] and [▼] keys. Press the [ENTER] key to store the value

**NOTE:** IF YOU INPUT A WRONG VALUE, PRESS THE [ESC] KEY TO RETURN BACK TO THE MAIN MEASURING PAGE AND REPEAT THE PROCEDURE.

The following page will appear:

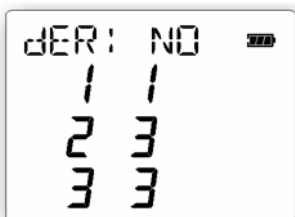

If during the smoke measurements you notice some petroleum derivatives on the filter paper, you have to input "YES" on the "der:" field by using the [PRINT] key.

- Press the [ENTER] key to store the value.
- Press [ESC] to return to the measure page.

## 6.4 Analysis Data Print

UniGas 1000 has two different possibilities to print the flue gas analysis data. You can use the optional internal impact printer or the standard IR port for your HP 82240B wireless thermal printer.

### 6.4.1 Built-In Printer (option)

You can order the UniGas 1000 complete with an internal 24-column impact printer. The printer is integrated with the instrument and the power is supplied by the same batteries as the analyzer. The impact model gives you one more advantage: more readability and long shelf life of your documents.

To print the data analysis follow the procedure:

- Wait for the stabilization of the measurement on the display. Press the [PRINT] key.
- The display shows the last setting for number of copies to be printed and the set document format.
- Check that the internal printer is enabled. Press the [MENU] key and verify that it displays the "PRINTINT" message.
- If you do not need any changes press the [PRINT] key again. The instrument will print the report as programmed
- If you need any changes, read the procedure on paragraph 6.3.3.



- Press [**ESC**] to return to the measuring page and analysis main page.

## 6.4.2 External Printer Port

**UniGas 1000** has a standard IR port compatible with your HP 82240B wireless thermal printer. The printer is external to the instrument and the power supply is separated from the analyzer. No connection cable is necessary: you can be near the printer IR led to the IR led of the analyzer.

To print the analysis data follow the procedure:

- Wait for the stabilization of the measure on this display. Press the [**PRINT**] key.
- The display shows the last setting for number of copies to be printed and the document format.
- Check that the internal printer is enabled. Press the [**MENU**] key and verify that it display the "**PRINTTEXT**" message.
- If you do not need any changes press the [**PRINT**] key again. The instrument will print the report as programmed
- If you need any changes, read the procedure on paragraph 6.3.3.
- Press [**ESC**] to return to the measure page.

## 6.4.3 Printer Settings

From the printer menu you can manage the following printer settings:

1. Format: **NORMAL** (to print a complete report) or **COMPACT** (to print a short report with the date and data analysis only)
  2. Printer type: **PRINTINT** (for the built-in printer) or **PRINTTEXT** (for the external optional printer)
  3. Number of copies: you can print up to 5 copies of the same report
  4. **FEED**: to output the paper without printing. When you press the [**ENTER**] key in this mode the paper will start to output without printing. Press the [**ENTER**] key again to stop the feed mode.
- Press the [**PRINT**] key to enter the printer menu.
  - The display shows the last setting for number of copies to be printed and the document format.
  - Press the [**MENU**] key until the parameter to be changed is displayed.
  - Press the [**▶**] key to change the value of the displayed parameter. Press the [**ENTER**] key to store the changes.
  - Press the [**MENU**] key to change the parameter.
  - Press the [**PRINT**] key to print the report.
  - Press [**ESC**] to return to the measure page.



## 6.4.4 Header Setting

Using the UniGas keyboard, you can set the report header (4 text rows of 16 char each) with your own data.

- Press the [MENU] key from measuring page until the following page is displayed:



- Press the [ENTER] key. Press the [MENU] key until the following page is displayed:



- Press the [ENTER] key. A number "1" on display will show you that you are changing the first line of the header.
- Press the [▲] and [▼] keys to change the first of 16 characters of the header row.

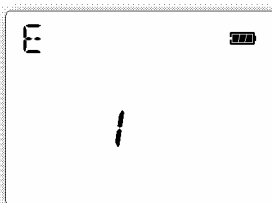

- Press the [◀] and [▶] keys to change the cursor position and change another character.



- Press the [ENTER] key to confirm the row inputs and change the second row.

Repeat the previous procedure to change the other header rows.

- Press [ESC] to return to the menu page.
- Press [ESC] to return to the measure page.



## 6.5 Carbon Monoxide Safety Room Test

A procedure can be selected to monitor the CO in ambient air using the internal sensors. An internal program allows the CO max measurement in atmospheric boiler room test with 15 values logging. An external optional probe is also available for continuous surveillance of the ambient and operator safety. Both acoustic and visual alarm are available.

- Remove any pneumatic connection from the **UniGas 1000** gas INLET.
- Press the **[MENU]** key until the following page will be displayed:



- Press the **[ENTER]** key to monitor ambient CO.

The test will detect and store the CO value for 15 times, one time per minute. The complete test time is 15 minutes. The instrument will display a 900 seconds countdown and the number of the already stored values on the third row on the display as shown on the page below:

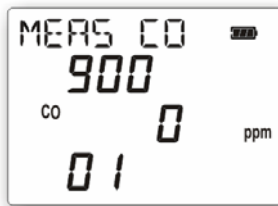

**NOTE: AMBIENT CO MONITORING IS ACTIVE ONLY ON “COAMBINT” OPERATIVE PAGE.**

- Press the **[PRINT]** key at the end of the test to print the report



Your company name  
Phone number here  
Fax number here

UniGas 2000 PLUS  
Serial Number 102597

Date: 02/10/2006  
Time: 14:41

CO room test  
Compliant to BS 7967  
Time CO  
01 : 14 PPM  
02 : 14 PPM  
03 : 14 PPM  
04 : 14 PPM  
05 : 14 PPM  
06 : 14 PPM  
07 : 15 PPM  
08 : 17 PPM  
09 : 17 PPM  
10 : 19 PPM  
11 : 20 PPM  
12 : 20 PPM  
13 : 20 PPM  
14 : 20 PPM  
15 : 20 PPM  
CO MAX : 20 PPM

## LEGEND

**01-15:** CO values stored one per minute in 15 minutes of overall testing time

**CO MAX:** the maximum detected CO value

- Press **[ESC]** to return to the measuring page.



## 7 CONFIGURATION

### 7.1 Engineering Units

Directly from the unit's keyboard, you can change the engineering units for the necessary measured parameters.

Gas concentration available units are: ppm, mg/m<sup>3</sup>, mg/kWh.

Temperature available units are: °C, °F.

Pressure available units are: hPa, mbar, Pa, mmH<sub>2</sub>O, inchH<sub>2</sub>O.

Follow these procedures:

- Press the **[MENU]** key from measuring page until the following page is displayed:



- Press the **[ENTER]**. Press the **[MENU]** key until the following page is displayed:

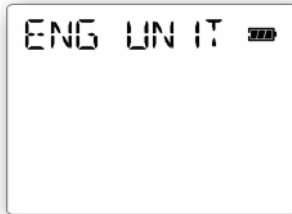

- Press the **[ENTER]** key to change the unit for the CO parameter.

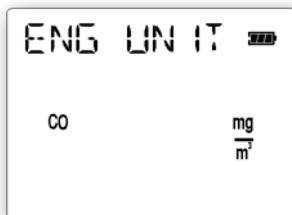

- Press the **[▲]** key to select one different unit.
- Press the **[ENTER]** key to store the changes and to modify the temperature unit.



- Press the [▲] key to select one different unit.
- Press the [ENTER] key to store the changes and to modify the pressure unit.



- Press the [▲] key to select one different unit.
- Press the [ENTER] key to store the changes.

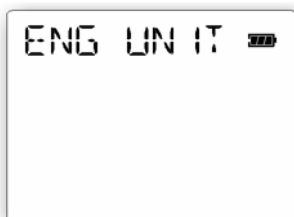

- Press [ESC] to return to the measure page.

## 7.2 Alarms

You can set up to 3 alarms related to 3 different (O<sub>2</sub>, CO, and Tair) measured parameters. Follow these procedures:

- Press the [MENU] key from measuring page until the following page is displayed:

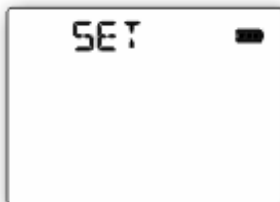



- Press the [ENTER]. Press the [MENU] key until the following page is displayed:



- Press the [ENTER] key to change the O<sub>2</sub> alarm level.



- Press the [▲] and [▼] keys to change the flashing digit. Press the [◀] and [▶] keys to select a different digit.
- Press the [ENTER] key to store the changes and modify the CO alarm level.



- Press the [▲] and [▼] keys to change the flashing digit. Press the [◀] and [▶] keys to select a different digit.
- Press the [ENTER] key to store the changes and modify the Tair alarm enable level.



- Press the [▲] and [▼] keys to change the flashing digit. Press the [◀] and [▶] keys to select a different digit.
- Press the [ENTER] key to store the changes.



Press **[ENTER]** key to enter settings for Tair disable levels. In these pages, the indication “Disable” appears instead of “Enable”.



- Press **[ESC]** to return to the measure page.

When one of the alarm levels is more than the reading, a continuous beep is generated by the analyzer. Press the **[ENTER]** key to mute the instrument.

**NOTE: YOU CAN DISABLE OR ENABLE ANY SINGLE ALARM BY PRESSING THE [DRAFT] KEY**

### 7.3 Measure Related to Oxygen Percentage

Directly from the instrument keyboard, it is possible to set the Reference Oxygen percentage for CO measurements. The normative related with your application will give you the correct value to input. The analysis printed report contains both measured and calculated CO values.

Pressing the **[REF. O<sub>2</sub>]** key the CO measured parameter will be displayed as referred to the programmed oxygen value. When selected this mode, the message “**REF O<sub>2</sub>CO**” will be displayed. Follow these procedures:

- Press the **[MENU]** key from measuring page until the following page is displayed:

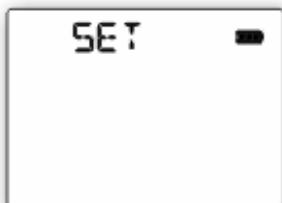

- Press the **[ENTER]**. Press the **[MENU]** key until the following page is displayed:

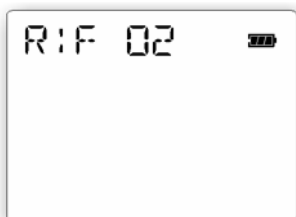

- Press the **[ENTER]** key to change the O<sub>2</sub> percentage.



- Press the [▲] and [▼] keys to change the flashing digit. Press the [◀] and [▶] keys to select a different digit.
- Press the [ENTER] key to store the changes.



- Press [ESC] to return to the measure page.

## 7.4 Clock Set-Up

Follow these procedures:

- Press the [MENU] key from measuring page until the following page is displayed:



- Press the [ENTER]. Press the [MENU] key until the following page is displayed:



- Press the [ENTER] key to enter in set-up mode.
- Press the [▲] and [▼] keys to change the flashing digit (Day). Press the [ENTER] key to store the changes.
- Press the [▲] and [▼] keys to change the flashing digit (Month). Press the [ENTER] key to store the changes.
- Press the [▲] and [▼] keys to change the flashing digit (Year). Press the [ENTER] key to store the changes.



- Press the [▲] and [▼] keys to change the flashing digit (Hour). Press the [ENTER] key to store the changes.
- Press the [▲] and [▼] keys to change the flashing digit (Minutes). Press the [ENTER] key to store the changes.
- Press [ESC] to return to the measure page.

## 7.5 Update Instrument to Instrument (Bootload)

UniGas 1000 is able to perform the firmware upgrade between 2 instruments (master and slave) of a same model.

**NOTE:** YOU SHOULD PERFORM AN UPGRADE ONLY IF THE FW VERSION OF THE SLAVE INSTRUMENT IS FOREGOING TO THAT ONE OF THE MASTER. OTHERWISE, YOU DO NOT NEED ANY OPERATION.

**IMPORTANT**  
TRANSFER THE FW JUST BETWEEN INSTRUMENTS OF THE SAME MODEL

To upgrade the firmware of an instrument of 2000 series, you must have the proper connection cable between the 2 instruments.

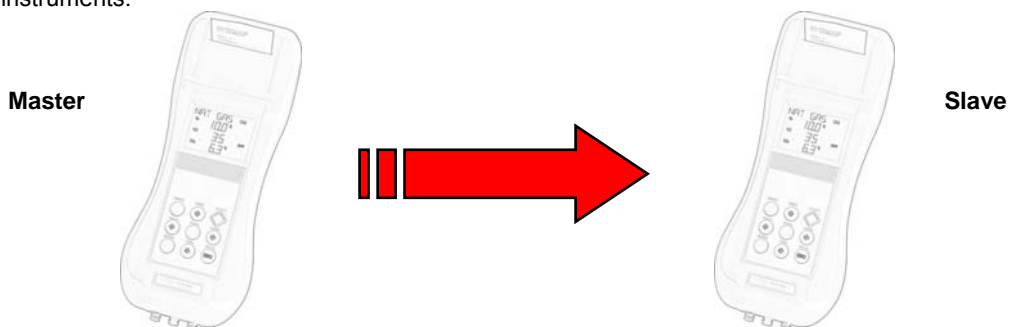

- Turn on the instrument slave in FW upgrade mode by pressing [MENU]+[ON]
- Turn on the instrument master
- Press [MENU] a number of time needed to display the following page:



Press [ENTER]. Press [MENU] a number of time needed to display the beside page



- Press [ENTER] to start data transfer:

**NOTE:** IN CASE OF A FAILURE, THE MESSAGE “BOOT KO” APPEARS

AT THE END OF OPERATION, THE SLAVE INSTRUMENT TURNS ON AUTOMATICALLY AND ON THE DISPLAY OF THE MASTER UNIT APPEARS “BOOT OK”



## 8 MAINTENANCE

The UniGas 1000 analyzer has been developed and manufactured using high quality components. A correct systematic maintenance will prevent damage and will increase the life of the instrument, and provide excellent results. Any conditions that require extraordinary maintenance interventions are promptly displayed, either clearly or with an information code.

### 8.1 Printer Maintenance

Open both the covers pressing as in figure, to change the paper and/or the ribbon.



Remove the exhausted paper roll. You can use standard paper, roll but you have to check before for its dimensions (max. 57mm  $\pm$ 1mm large).

If necessary substitute the ribbon cartridge (cod. EE490002).

Approach the end of the new paper roll (cod. EE340006) to the slot under the printer.

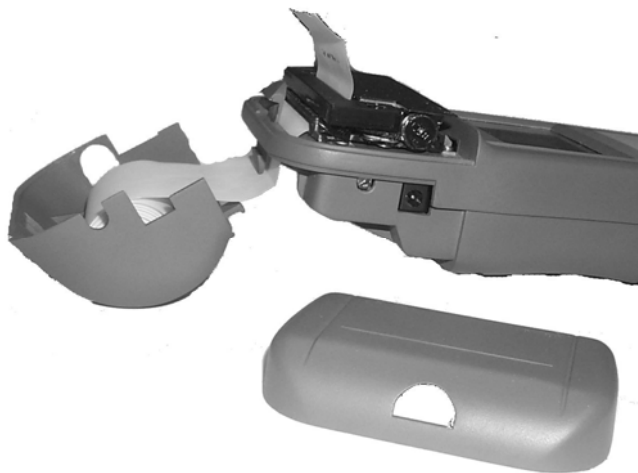

Turn on the analyzer on.

Press the **[PRINT]** key down; press the **[MENU]** key until the "FEED" message is displayed.

Press **[ENTER]** for paper feed. Press the **[ESC]** key when the paper will come out for some centimeters.

Close the cover inserting the paper end in its slot.



## 8.2 Smoke Pump Maintenance

### Gas-Tight Checking

To have a correct measurement the pump should be gas-tight. Turn the screw and close the probe with your finger. Pull the plunger for 3 cm and verify that the gasket does not leak from the vacuum. If a leak is found the gasket needs to be lubricated. When you push the plunger the valve must close immediately to have a 1.9/2.0 liters of air with 10 shoots. The correct smoke index can be obtained only if the pump works correctly.

### Service

1. Clean and lubricate the cylinder the stem and the gasket every 30 measurements.
2. Wash using alcohol if the valve is not gas-tight
3. Clean the probe and the paper support
4. Check the pump for gas-tight
5. Use only clean paper filters and a readable scale index table

## 8.3 Error Messages

UniGas performs the auto diagnostic procedure when switched on. When measuring it checks also for anomalous conditions. If analyzer finds trouble, it displays an error for the related parameters. Printing the report, the error messages will be printed. Sometimes these messages correspond to an unrecoverable problem and it is necessary to return the instrument to Eurotron for maintenance. Frequently these messages are referred to a recoverable trouble and can be solved by you.

The following table shows the possible UniGas error messages:

Error message	Problem	Solutions
Calc Err	Parameter calculations error.	The instrument cannot perform the calculations. Check and solve the others error conditions.
Probe Er	The external Rtd probe is disconnected or damaged.	Connect or replace the external temperature probe.
RJ Err	Internal temperature reference damaged.	Return the instrument to Eurotron for maintenance
Over	Over range condition	The problem is solved automatically when measure return inside the range
Under	Under range condition	The problem is solved automatically when measure return inside the range
-----	No calculus available	The instrument cannot perform the calculus. Check and solve the others error conditions. (e.g. O <sub>2</sub> >18%).
Excluded	CO sensor excluded by electro-valve	Automatic CO sensor protection is active. Perform one or more autozero cycles in fresh air.
Tc Error	The thermocouple is disconnected or damaged.	Connect or replace the temperature probe.
Tsens Er	Cell compensation error	Return the instrument to Eurotron for maintenance.
Zero Err	The autozero procedure is failing	Perform one or more autozero cycles in fresh air. If the problem remains, Return the instrument to Eurotron for maintenance.
Sens. Er	Broken cell	Return the instrument to Eurotron for maintenance.
No sens.	The cell is non installed	
No probe	No external probe connected on mini-din connector.	Connect or replace the temperature probe.



## 8.4 Display Battery Level

- Press the [MENU] key from measuring page until the following page is displayed: times until.



- Press [ENTER]. Press [MENU] a number of "battery" is displayed.



- This page shows the actual voltage level of the battery

## 8.5 Accessories and Spare Parts

### Accessories

BB880043	Vinyl carrying case with shoulder strap
BB880028	ABS Rigid carrying case
BB880033	Aluminium carrying case
F7828000	Manual pump for smoke measurement
BB610057	3 m long extension gas hose

### Gas Sampling Probes

BB610046	300mm standard max 800°C + draft (double hose)
----------	--

### Battery Chargers

BB290029	115V 50/60 Hz USA plug
BB290027	230V 50/60 Hz Schuko plug
BB290028	230V 50/60 Hz UK plug
BB290026	230V 50/60 Hz European plug
BB290030	100V 50/60 Hz USA/Japan plug
BB290031	DC auto adapter

### Consumable Parts

EE340006	Printer paper roll 58 mm x 10 meters long
EE490002	Printer ribbon cartridge
EE650074	Line Filter cartridge for EE650076 water trap
EE860004	Smoke index comparing table
EE650011	Filter for smoke measurement (set of 40 pcs.)
EE650076	Water trap
EE650082	Water trap complete of hose and connector
EE650081	Rubber plug for EE650076 water trap
EE300178	Precalibrated Oxygen sensor kit



## 9 CERTIFICATES

### 9.1 Warranty Terms

**Eurotron Instruments** warrants its products against defects in materials and workmanship for the period declared from the date of the original retail purchase.

This warranty applies to the original purchaser only.

If the unit should malfunction, it must be returned during the warranty period, transportation prepaid, to **Eurotron** for evaluation. Upon examination, if the unit is found to be defective it will be repaired or replaced at no charge.

Direct all warranty and repair requests/inquiries to the **Eurotron** Customer Service Department. BEFORE RETURNING ANY PRODUCT(S) TO **EUROTRON**, PURCHASER MUST OBTAIN AN AUTHORIZED RETURN (AR) NUMBER FROM **EUROTRON'S** CUSTOMER SERVICE DEPARTMENT (IN ORDER TO AVOID PROCESSING DELAYS).

Please include a copy of the original invoice or a small service charge may be applied.

The purchaser is responsible for shipping charges, freight, insurance and proper packaging to prevent breakage in transit.

**Eurotron's** WARRANTY does not apply to defects resulting from any action of the purchaser, including but not limited to mishandling, improper interfacing, operation outside of design limits, improper repair, or unauthorized modification. This WARRANTY is VOID if the unit shows evidence of having been tampered with or shows evidence of being damaged as a result of excessive corrosion; or current, heat, moisture or vibration; improper specification; misapplication; misuse or other operating conditions outside of **Eurotron's** control.

### 9.2 Letter of Conformity

This is to certify that the instrument has been manufactured and inspected to document procedures and where applicable, calibrated against standards which are traceable to National and International Standards.

The Instrument has been found to conform in all respects to specifications, drawings, workmanship standards and work order requirements.



## **APPENDIX**

### **A1      EMC Conformity**

The instrument case made in shock-resistant injection moulded ABS + polycarbonate has an internal metal coating to fulfill the provision of the directive 89/336/CEE Electromagnetic Compatibility.



## Declaration of Conformity

**We :** Eurotron Instruments S.p.A.

(Supplier's name)

Viale F.lli Casiraghi 409/423 20099 Sesto S. Giovanni (MI) - Italy

(Address)

**declare under our sole responsibility that the product :**

Palmtop flue gas analyser mod. UniGas 1000

(Name and type)

cat. 7820

(Model)

**to which this declaration relates is in conformity with the following normative documents :**

EN 50082-1 (8/97)

IEC 1000-4-2 / IEC 1000-4-4 / IEC 1000-4-11

ENV 50140 - ENV 50141 - ENV 50204

EN 55011

(Title, number and date of issue of normative documents)

**following the prevision of directive :**

89/336/CEE Electromagnetic Compatibility (EMC)



## INDEX

- A**
- Accessories; 42
  - Accuracies and ranges; 6
  - Alarms; 35
  - Analysis data print; 30
  - APPENDIX; 44
  - Auxiliary measure; 11
- B**
- Backlight; 8
  - Bootload; 39
  - Built-in printer; 30
  - Burner pressure measurement; 21
- C**
- Calibration certificate; 6
  - Carbon Monoxide Safety Room Test; 32
  - CERTIFICATES; 43
  - Chargers; 42
  - Clock set-up; 38
  - Condensating Boiler; 18
  - CONFIGURATION; 34
  - CONNECTIONS; 14
  - Consumable parts; 42
- D**
- Declaration of Conformity UniGas 2000+; 45**
  - Display; 8
  - Display battery level; 42
  - Draft; 11
  - Draft with External Probe; 21
- E**
- Electromagnetic compatibility; 6
  - Electro-pneumatic connections; 14
  - EMC Conformity; 44
  - Engineering Units; 34
  - Error messages; 41
  - External printer port; 30
- F**
- Features and Benefits; 4
  - Flue Gas Analysis; 17
  - Fuel technical data; 6
  - Fuel type set-up; 18
  - functional blocks; 9
- G**
- Gas analysis; 16
  - Gas probe positioning; 14
  - Gas sampling probe; 9; 42
  - Gas sensors; 10
  - GENERAL DESCRIPTION; 4
- H**
- Header setting; 31
- K**
- Keyboard; 8
- L**
- Leak Test Procedures; 24
  - Let-by Test; 24
  - Letter of conformity; 43
  - line filter; 10
- M**
- MAINTENANCE; 40
  - Measure related to Oxygen percentage; 37
  - Measurement principle; 9
  - Measuring instruments; 12
- O**
- OPERATIONS; 16
  - Ordering code; 5
- P**
- Paper replacement; 40
  - PHYSICAL DESCRIPTION; 7
  - Power supply; 13
  - Pressure; 11
  - Pressure kit; 28
  - Pressure/Draft measurement; 19
  - PRINCIPLE OF OPERATION; 9
  - Printer maintenance; 40
  - Printer settings; 31
- R**
- RECOMMENDATIONS; 13
  - Ribbon replacement; 40



## **S**

Smoke index input; 29  
Smoke index measurement; 12  
Smoke measurement; 28  
Smoke pump maintenance; 41  
Specifications; 5  
Switch the instrument ON; 16  
Symbols on display; 8

## **T**

Temperature Measurement; 23  
Temperature measurements; 11

Tightness test; 26

## **U**

Update instrument to instrument; 39

## **W**

Warranty terms; 43  
Water trap; 10